

# **1000 Induction**

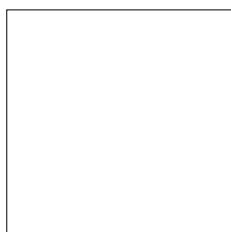

## **User Guide**

&

Installation & Service Instructions

# **MERCURY**

U110145 - 01

# Contents

---

<b>1. Before You Start...</b>	<b>1</b>	<b>6. Troubleshooting</b>	<b>17</b>
Installation and Maintenance	1		
Peculiar Smells	1	<b>7. Installation</b>	<b>19</b>
Ventilation	1	Dear Installer	19
Personal Safety	1	Safety Requirements and Regulations	19
Hob Care	2	Provision of Ventilation	19
Cooker Care	2	Location of Cooker	19
Cleaning	2	Positioning the Cooker	20
<b>2. Cooker Overview</b>	<b>3</b>	Moving the Cooker	20
The Hob	3	Fitting the Flue and Vent	21
The Ovens	8	Fitting the Side Panel and Obscuring Trims	22
Accessories	10	Repositioning the Cooker following Connection	23
<b>3. Cooking Tips</b>	<b>11</b>	Levelling	23
Cooking with a Multi-function Oven	11	Electrical Connection	24
General Oven Tips	11	Final Checks	24
<b>4. Cooking Table</b>	<b>12</b>	Final Fitting	25
<b>5. Cleaning Your Cooker</b>	<b>13</b>	Customer Care	25
Hob	13	<b>8. Circuit Diagrams</b>	<b>26</b>
Glide-out Grill	14	Circuit Diagram: Hob	26
Control Panel and Oven Doors	14	Circuit Diagram: Ovens	27
Ovens	15	<b>9. Technical Data</b>	<b>28</b>
The Tall Oven	15		
Cleaning Table	16		

# 1. Before You Start...

Thank you for buying a this cooker. It should give you many years of trouble-free cooking if installed and operated correctly. It is important that you read this section before you start, particularly if you have not used an induction cooker before.

**⚠ This appliance is designed for domestic cooking only. Using it for any other purpose could invalidate any warranty or liability claim. In particular, the oven should NOT be used for heating the kitchen – besides invalidating claims this wastes fuel and may overheat the control knobs.**

## Installation and Maintenance

The electrical installation should be in accordance with BS 7671. Otherwise, all installations must be in accordance with the relevant instructions in this booklet, with the relevant national and local regulations, and with the local electricity supply companies' requirements.

Make sure that the cooker is wired in and switched on.

**The hob control display will flash for about 2 seconds during first power setting – this is normal.**

The cooker should be serviced only by a qualified service engineer, and only approved spare parts should be used.

Always allow the cooker to cool and then switch it off at the mains before cleaning or carrying out any maintenance work, unless specified otherwise in this guide.

## Peculiar Smells

**⚠ When you first use your cooker it may give off a slight odour. This should stop after use.**

Before using for the first time, make sure that all packing materials have been removed and then, to dispel manufacturing odours, turn the ovens to 200°C and run for at least an hour.

Before using the grill for the first time you should also turn on the grill and run for 15 minutes with the grill pan in position, pushed fully back, and the grill door open.

Make sure the room is well ventilated to the outside air (see 'Ventilation' below). People with respiratory or allergy problems should vacate the area for this brief period.

## Ventilation

The use of a cooking appliance results in the production of heat and moisture in the room in which it is installed. Therefore, make sure that the kitchen is well ventilated – keep natural ventilation holes open or install a powered cooker hood that vents outside. If you have several hotplates on, or use the cooker for a long time, open a window or turn on an extractor fan.

## Personal Safety

**Important information for pacemaker and implanted insulin pump users:** The functions of this hob comply with the applicable European standards on electromagnetic interference. If you are fitted with a pacemaker or implanted insulin pump and are concerned please consult your doctor for medical advice.

**⚠ DO NOT modify this appliance.**

**⚠ This appliance is not intended for use by persons (including children) with reduced physical, sensory or mental capabilities, or lack of experience and knowledge, unless they have been given supervision or instruction concerning use of the appliance by a person responsible for their safety.**

**⚠ This appliance is not intended for use by young children or infirm persons unless they have been adequately supervised by a responsible person to make sure that they can use the appliance safely.**

**⚠ DO NOT use a steam cleaner to clean the cooker.**

**⚠ When the hob is in use keep magnetic items, such as credit and debit cards, floppy disk, calculators, etc. away.**

**⚠ Accessible parts will become hot during use and will retain heat even after you have stopped cooking. Keep babies and children away from the cooker and never wear loose-fitting or hanging clothes while the appliance is in use.**

**⚠ Always be certain that the controls are in the OFF position when the oven is not in use, and before attempting to clean the cooker.**

**⚠ Take care when touching the marked cooking areas of the hob.**

**⚠ When the oven is on, DO NOT leave the oven door open for longer than necessary, otherwise the control knobs may become very hot.**

**⚠ When using the grill, make sure that the grill pan is in position and pushed fully in, otherwise the control knobs may become very hot.**

**⚠ Note that this appliance has a cooling fan. When the oven or grill is in operation the fan will run to cool the fascia and control knobs.**

Cooking high moisture content foods can create a 'steam burst' when the oven door is opened. When opening the oven stand well back and allow any steam to disperse.

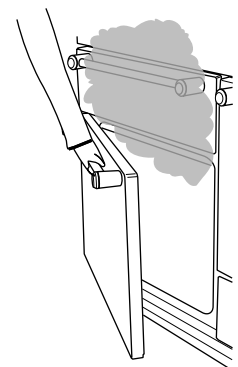

Always keep combustible materials, e.g. curtains, and flammable liquids a safe distance away from your cooker.

- ⚠ DO NOT spray aerosols in the vicinity of the cooker while it is on.**
- ⚠ Use dry oven gloves when applicable – using damp gloves might result in steam burns when you touch a hot surface. Do not use a towel or other bulky cloth in place of a glove – it might catch fire if brought into contact with a hot surface.**
- ⚠ NEVER operate the cooker with wet hands.**
- ⚠ DO NOT use aluminium foil to cover shelves, linings or the oven roof.**
- ⚠ NEVER heat unopened food containers. Pressure build up may make the containers burst and cause injury.**
- ⚠ DO NOT use unstable saucepans. Always make sure that you position the handles away from the edge of the hotplate.**

Never leave the hotplate unattended at high heat settings. Pans boiling over can cause smoking, and greasy spills may catch on fire. Use a deep fat thermometer whenever possible to prevent fat overheating beyond the smoking point.

NEVER leave a chip pan unattended. Always heat fat slowly, and watch as it heats. Deep fry pans should be only one third full of fat. Filling the pan too full of fat can cause spill over when food is added. If you use a combination of oils or fats in frying, stir them together before heating, or as the fats melt.

Foods for frying should be as dry as possible. Frost on frozen foods or moisture on fresh foods can cause hot fat to bubble up and over the sides of the pan. Carefully watch for spills or overheating of foods when frying at high or medium high temperatures. NEVER try to move a pan of hot fat, especially a deep fat fryer. Wait until the fat is cool.

DO NOT use the top of the flue (the slot along the back of the cooker) for warming plates, dishes, drying tea towels or softening butter.

- ⚠ DO NOT use water on grease fires and never pick up a flaming pan. Turn off the controls and then smother a flaming pan on a surface unit by covering the pan completely with a well-fitting lid or baking tray. If available, use a multipurpose dry chemical or foam-type fire extinguisher.**

**⚠ This appliance is heavy so take care when moving it.**

## Hob Care

- ⚠ DO NOT use the hob surface as a cutting board.**

DO NOT leave utensils, foodstuffs or combustible items on the hob when it is not in use (e.g. tea towels, frying pans containing oil).

- ⚠ DO NOT place plastic or aluminium foil, or plastic containers, on the hob.**
- ⚠ DO NOT leave the hob zones switched on unless being used for cooking.**

- ⚠ NEVER allow anyone to climb or stand on the hob.**

DO NOT stand or rest heavy objects on the hob. Although the ceramic surface is very strong, a sharp blow or sharp falling object (e.g. a salt cellar) might cause the surface to crack or break.

- ⚠ Should a crack appear in the surface, disconnect the appliance immediately from the supply and arrange for its repair.**

Always LIFT pans off the hob. Sliding pans may cause marks and scratches. Always turn the control to the OFF position before removing a pan.

**DO NOT** place anything between the base of the pan and the hob surface (e.g. asbestos mats, aluminium foil, wok stand).

Care should be taken that no water seeps into the appliance.

Only certain types of stainless steel, enamelled steel pans or cast iron pans with enamelled bases are suitable for induction hob cooking.

The ceramic surface should be washed after use to prevent it from becoming scratched or dirty. However, you should clean the hob with caution as some cleaners can produce noxious fumes if applied to a hot surface.

**DO NOT use abrasive cleaners/pads, oven aerosols/pads or stain removers on the surface.**

We recommend that you avoid wiping any surface unit areas until they have cooled and the indicator light has gone off. Sugar spills are the exception to this (see 'Cleaning your Cooker'). After cleaning, use a dry cloth or paper towel to remove any cleaning cream residue.

## Cooker Care

As steam can condense to water droplets on the cool outer trim of the oven, it may be necessary during cooking to wipe away any moisture with a soft cloth. This will also help to prevent soiling and discolouration of the oven exterior by cooking vapours.

## Cleaning

In the interests of hygiene and safety, the cooker should be kept clean at all times as a build up in fats and other food stuff could result in a fire.

Clean only the parts listed in this guide.

Clean with caution. If a wet sponge or cloth is used to wipe spills on a hot surface, be careful to avoid steam burns. Some cleansers can produce noxious fumes if applied to a hot surface.

## 2. Cooker Overview

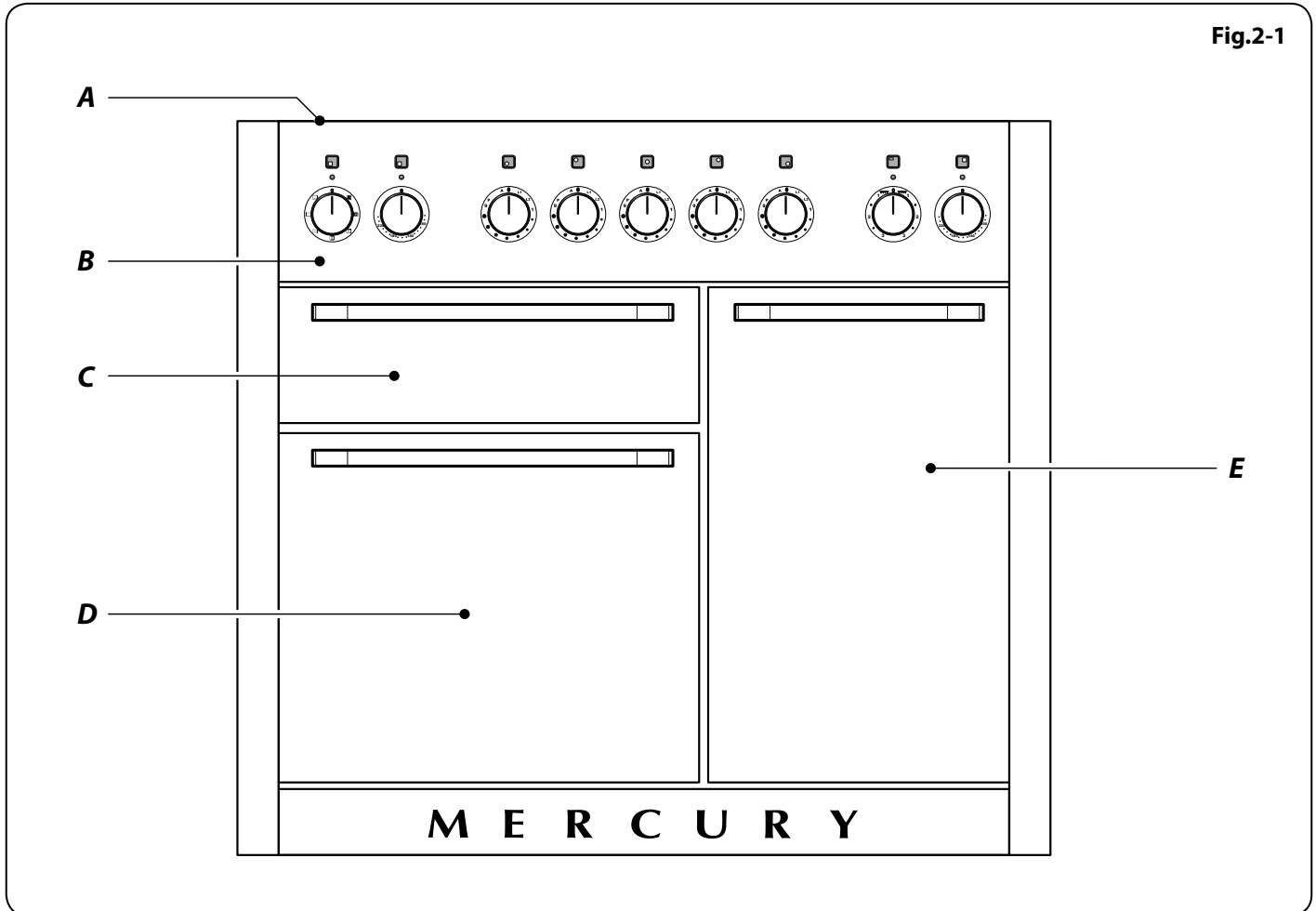

The 1000 induction cooker (**Fig.2-1**) has the following features:

- A.** 5 induction cooking zones
- B.** A control panel
- C.** A glide-out grill
- D.** Main multi-function oven
- E.** Tall fan oven

### The Hob

Use only pans that are suitable for induction hobs. We recommend stainless steel, enamelled steel pans or cast iron pans with enamelled bases. Note that some stainless steel pans are not suitable for use with an induction hob so please check carefully before purchasing any cookware.

Pans made of copper, aluminium or ceramic are not suitable for use on an induction hob. The kind of pan you use and the quantity of food affects the setting required. Higher settings are required for larger quantities of food.

Pots and pans should have thick, smooth, flat bottoms (**Fig.2- 2**). This allows the maximum heat transfer from the hob to the pan, making cooking quick and energy efficient. Never use a round-bottomed wok, even with a stand.

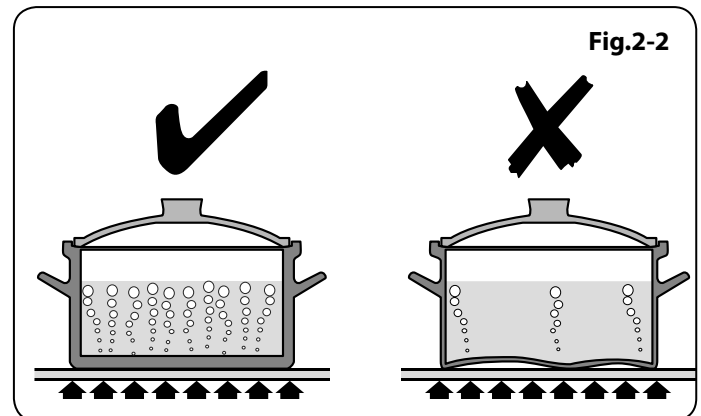

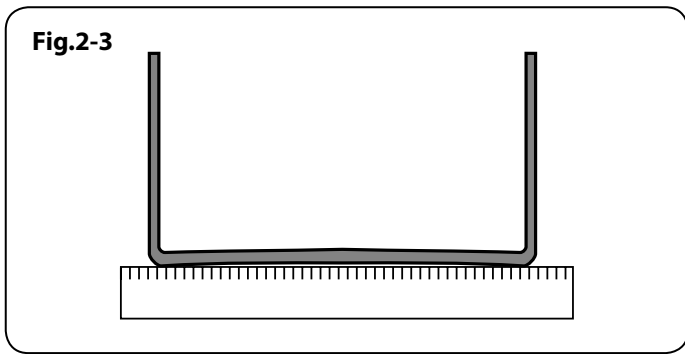

The very best pans have bases that are very slightly curved up when cold (**Fig.2-3**). If you hold a ruler across the bottom you will see a small gap in the middle. When they heat up the metal expands and lies flat on the cooking surface.

Make sure that the base of the pan is clean and dry to prevent any residue burning onto the hob panel. This also helps prevent scratches and deposits.

Always use pans that are the same size as (or slightly larger than) the areas marked on the hob. Using a lid will help the contents boil more quickly.

**⚠ Always take care before touching the surface, even when the hob is turned off. It may be hotter than you think!**

The induction hob comprises of five cooking zones containing induction elements with different ratings and diameters (**Fig.2-4**) each with a pan detector and residual heat indicator, and a hob control display.

The hob control display (**Fig.2-5**) informs you of the following induction hob functions:

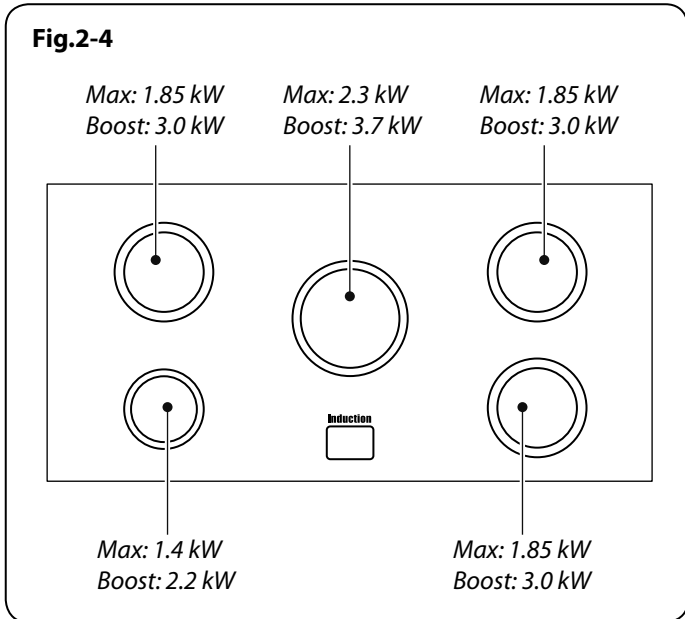

- ☒ Pan detector
- H Residual heat indicator
- A Automatic heat-up
- 🔒 Child lock
- L1/L2 Low temperature/simmer setting
- P Power boost setting

### Pan detector, ☒

**IMPORTANT:** After use, switch off the hob element by its control and DO NOT RELY on the pan detector.

If a cooking area is switched on and there is no pan in place or if the pan is too small for the cooking area, then no heat will be generated. The symbol [☒] will appear on the hob control display; this is the “pan-missing symbol”. Place a pan of the correct size on the cooking area and the [☒] will disappear and cooking can begin. After 10 minutes without detecting a pan the cooking zone will switch off automatically.

**Table 2-1** shows the minimum pan sizes recommended for each cooking zone.

**Note:** Using pans with a base diameter smaller than those recommended will result in a power reduction.

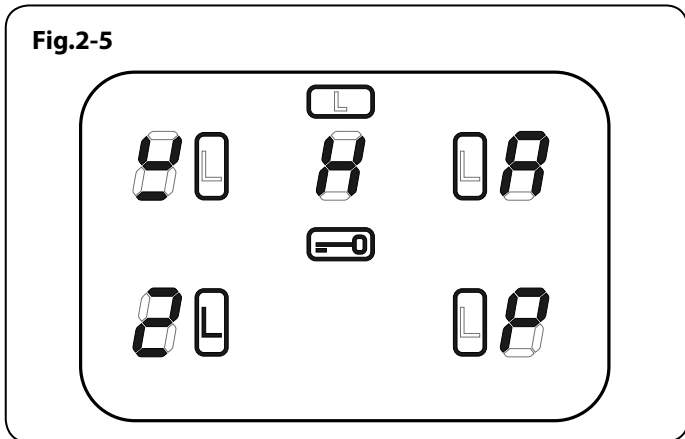

### Residual Heat Indicator, H

After use, a cooking zone will remain hot for a while as heat dissipates. When a cooking zone is switched off the residual heat indicator symbol [H], will appear in the display. This shows that the cooking zone temperature is above 60°C and may still cause burns. Once the temperature has dropped to below 60°C the [H] will go out.

Cooking zone	Minimum Pan Diameter (Pan base) mm
Front left	120
Rear left	140
Centre	160
Rear right	140
Front right	140

**Table 2-1**

## Automatic Heat-up, $\mathcal{A}$

This function is available on all of the cooking zones. It allows rapid heating up of the element to bring the selected cooking zone up to temperature. Once the zone is at the required cooking temperature the power level will reduce automatically to the preset level.

The function is selected by turning the control knob to the 'A' position. This can be selected by turning the control knob momentarily counter-clockwise from the zero position until the symbol  $\mathcal{A}$  is shown on the hob control display.

Once the  $\mathcal{A}$  is displayed, turn the control knob to the level of your choice (1 to 9). The pan will heat up at 100% power for a specified time before the power is reduced to the level selected.

When the Automatic Heat-up function is activated, the hob control display will flash alternately between the  $\mathcal{A}$  setting and the chosen power level.

Once the automatic heat-up time has ended the hob display will stop flashing and will show the chosen power level.

The Automatic Heat-up function can be stopped by either turning the control knob back to the "0" power setting or turning the control knob to the "9" power setting.

For your guidance **Table 2-2** shows the time available at 100% power depending on the power level selected in the Automatic Heat-up mode.

## Child Lock,

To prevent the unwanted use by children, the hob can be locked.

**IMPORTANT: This can only be activated when all the cooking zones are switched off.**

To lock the hob, simultaneously turn the two left-hand controls counter-clockwise (**Fig.2-6**) and hold until the  symbol appears in the centre of the hob control display (**Fig.2-7**).

**Note:**  $\mathcal{A}$  will flash when locking the hob – this is normal.

Locking the hob will NOT affect the oven; it can still be used.

To unlock the hob, simultaneously turn the two left-hand controls counter-clockwise and hold until the  symbol disappears from the centre of the hob control display.

## Low Temperature/Simmer Setting, $L1/L2$

Each cooking area is equipped with 2 low temperature settings:

- $L1$  will maintain a temperature of about 40°C\*
- $L2$  will maintain a temperature of about 80°C\*

\* This will vary slightly depending on the pan being used.

These settings will maintain a temperature:  $L1$  is useful for melting butter or chocolate without it burning, and  $L2$  will keep water that has been brought to the boil very gently simmering.

The maximum time this setting can be used is 2 hours. To increase the heat, just turn the control knob to the required level.

Power level	Automatic heat-up time at 100% (min:sec)
1	0:48
2	2:24
3	3:50
4	5:12
5	6:48
6	2:00
7	2:48
8	3:36
9	

**Table 2-2**

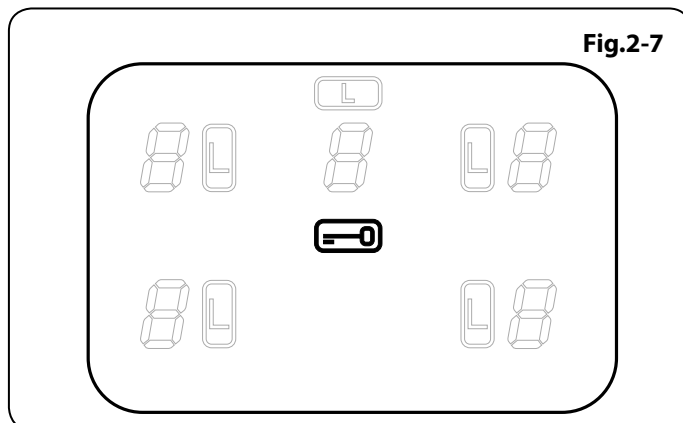
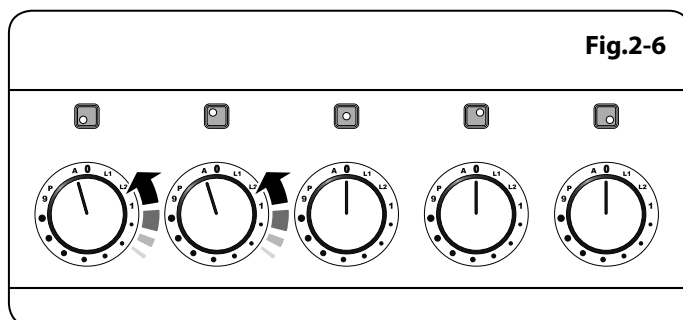

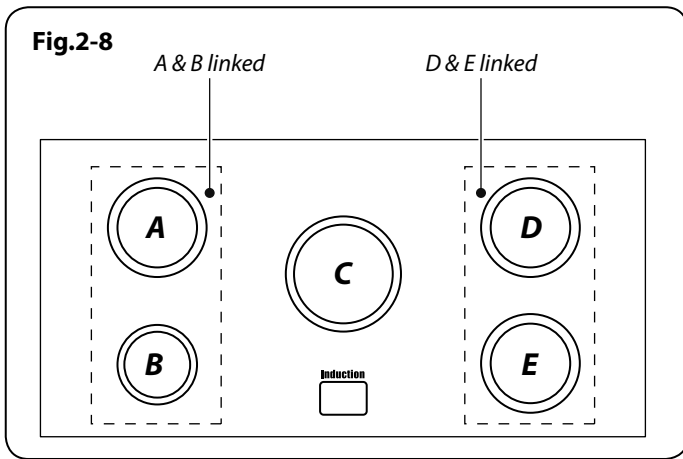

### Power Boost Setting, *P*

All of the induction cooking zones have Power Boost available, activated by turning the control knob clockwise until [*P*] is shown on the hob control display.

Power Boost allows additional power to be made available for each of the cooking zones. This is useful to bring a large pan of water to the boil quickly.

The Power Boost function operates for a maximum of 10 minutes on each zone, after which the power is automatically reduced to setting 9.

When using the Power Boost function, the cooking zones are linked.

**Fig.2-8** shows the hob layout. Zones A and B are linked together as are zones D and E.

This means that when using zone A on power boost and then switching zone B to power boost, then the power to zone A will reduce slightly. The last zone switched to power boost always takes priority. Zones D and E work in the same way.

#### **⚠ This is a built in safety device.**

Deactivate the Power Boost function by turning the control knob to a lower setting.

### Overheat Function

This function identifies when the temperature of the pan rises rapidly and works to maintain a safe level of pan temperature.

It should not interfere with normal cooking.

#### **⚠ Please remember not to leave the hob unattended. Care should be taken to not allow your cookware to boil dry.**

## The Glide-out Grill

Open the door and pull the grill pan carriage forward using the handle (**Fig.2-9**).

The grill has two elements that allow either the whole area of the pan to be heated or just the right-hand half.

Adjust the heat to suit by turning the knob. To heat the whole grill, turn the knob clockwise (**Fig.2-10**).

To heat the right-hand half, turn the knob counter-clockwise. The neon indicator light by the grill control will come on.

For best results, slide the carriage back into the grill chamber and preheat the appropriate part(s) of the grill for two minutes. The grill trivet can be removed and the food placed on it while you are waiting for the grill to preheat.

**⚠ DO NOT leave the grill on for more than a few moments without the grill pan underneath it, otherwise the knobs may become hot.**

Once the grill has preheated, slide the carriage out again. With the trivet back in place with the food on it, slide the carriage back into the grill chamber. Make sure that it is pushed right in.

**⚠ Accessible parts may be hot when the grill is in use. Young children should be kept away.**

The grill pan trivet can be set to four different grilling heights by a combination of turning it back to front and turning it upside down (**Fig.2-11**).

**⚠ Never close the grill door when the grill is on.**

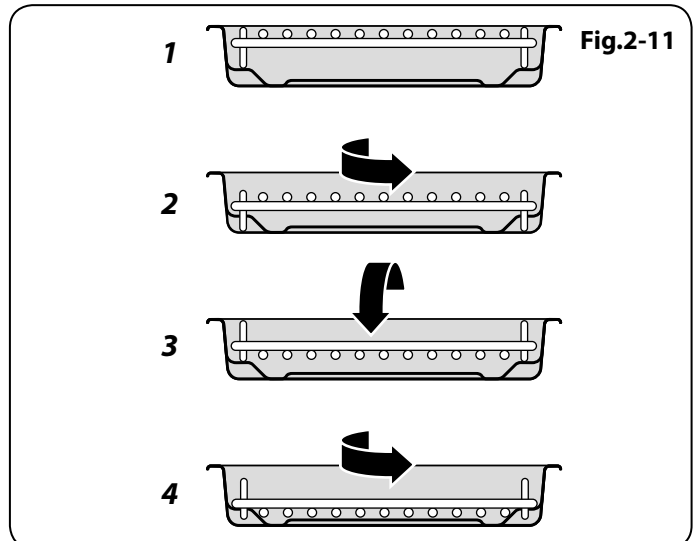
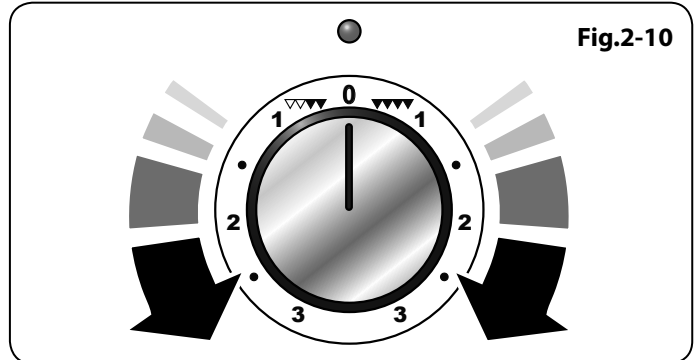
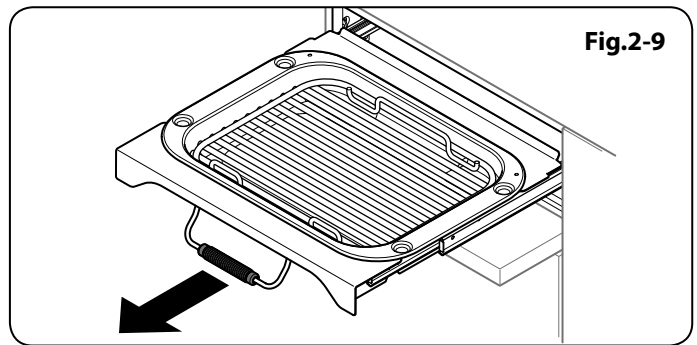

## The Ovens

References to 'left-hand' and 'right-hand' ovens apply as viewed from the front of the appliance.

The left-hand oven is a multi-function oven, while the right-hand oven is a fan oven.

### The Left-Hand Multi-function Oven

As well as the oven fan and fan element, they are fitted with two extra heating elements, one visible in the top of the oven and the second under the oven base. Take care to avoid touching the top element and element deflector when placing or removing items from the ovens.

The multi-function oven has 3 main cooking functions, fan, fan assisted and conventional cooking. These functions should be used to complete most of your cooking.

The browning element and base heat can be used in the latter part of the cooking process to fine tune the results to your particular requirements.

Use fanned grilling for all your grilling needs and defrost to safely thaw small items of frozen food.

**Table 2-3** gives a summary of the multi-function modes.

The multi-function ovens have many varied uses. We suggest you keep a careful eye on your cooking until you are familiar with each function. Remember – not all functions will be suitable for all food types.

Please remember that all cookers vary – temperatures in your new ovens may differ to those in your previous cooker.

### Multi-function oven functions

#### Defrost



This function operates the fan to circulate cold air only. No heat is applied. This enables small items such as desserts, cream cakes and pieces of meat, fish and poultry to be defrosted.

Defrosting in this way speeds up the process and protects the food from flies. Pieces of meat, fish and poultry should be placed on a trivet, over a tray to catch any drips. Be sure to wash the trivet and tray after defrosting.

Defrost with the oven door closed.

Large items, such as whole chickens and joints should not be defrosted in this way. We recommend this be carried out in a refrigerator.

Defrosting should not be carried out in a warm oven or when an adjoining oven is in use or still warm.

Make sure that dairy foods, meat and poultry are completely defrosted before cooking.

#### Fan oven



This function operates the fan and the heating element around it. An even heat is produced throughout the oven, allowing you to cook large amounts quickly.

Fan oven cooking is particularly suitable for baking on several shelves at one time and is a good 'all-round' function. It may be necessary to reduce the temperature by approximately 10 °C for recipes previously cooked in a conventional oven.

If you wish to preheat the oven, wait until the indicator light has gone out before inserting the food.

#### Fanned grilling



This function operates the fan whilst the top element is on. It produces a more even, less fierce heat than a conventional grill. For best results, place the food to be grilled, on a grid over a roasting tin, which should be smaller than a conventional grill pan. This allows greater air circulation. Thick pieces of meat or fish are ideal for grilling in this way, as the circulated air reduces the fierceness of the heat from the grill.

The oven door should be kept closed while grilling is in progress, so saving energy.

You will also find that the food needs to be watched and turned less than for normal grilling. Preheat this function before cooking.

#### Fan assisted oven



This function operates the fan, circulating air heated by the elements at the top and the base of the oven. The combination of fan and conventional cooking (top and base heat) makes this function ideal for cooking large items that need thorough cooking, such as a large meat roast.

It is also possible to bake on two shelves at one time, although they will need to be swapped over during the cooking time, as the heat at the top of the oven is greater than at the base, when using this function.

This is a fast intensive form of cooking; keep an eye on the food cooking until you have become accustomed to this function.

#### Conventional oven (top and base heat)



This function combines the heat from the top and base elements. It is particularly suitable for roasting and baking pastry, cakes and biscuits.

Food cooked on the top shelf will brown and crisp faster than on the lower shelf, because the heat is greater at the top of the oven than at the base, as in 'Fan assisted oven' function. Similar items being cooked will need to be swapped around for even cooking. This means that foods requiring different temperatures can be cooked together, using the cooler zone in the lower half of the oven and hotter area to the top.

### Browning element



This function uses the element in the top of the oven only. It is a useful function for the browning or finishing of pasta dishes, vegetables in sauce, shepherds pie and lasagne, the item to be browned being already hot before switching to the top element.

### Base heat



This function uses the base element only. It will crisp up your pizza or quiche base or finish off cooking the base of a pastry case on a lower shelf. It is also a gentle heat, good for slow cooking of casseroles in the middle of the oven or for plate warming.

The Browning and Base heat functions are useful additions to your oven, giving you flexibility to finish off items to perfection.

### Right-hand fan oven

The right-hand oven is a fan oven that circulates hot air continuously, which means faster, more even cooking.

The recommended cooking temperatures for a fan oven are generally lower than a conventional oven.

**Note:** Please remember that all cookers vary so temperatures in your new ovens may differ to those in your previous cooker.

### Operating the Ovens

#### Operating the left-hand multi-function oven

The multi-function oven has two controls: a function selector and a temperature setting knob (**Fig.2-12**).

Turn the function selector control to a cooking function.

**Fig.2-13** shows the control set for convectional oven cooking.

Turn the oven temperature knob to the temperature required (**Fig.2-13**).

The oven heating light will glow until the oven has reached the temperature you selected. It will then cycle on and off during cooking as the oven maintains the selected temperature.

#### Operating the right-hand fan oven

Turn the oven knob to the desired temperature (**Fig.2-14**).

The oven indicator light will glow until the oven has reached the temperature selected. It will then cycle on and off during cooking (**Fig.2-15**).

Function	Use
<b>Defrost</b>	To thaw small items in the oven without heat
<b>Fan oven</b>	A full cooking function, even heat throughout, great for baking
<b>Fanned grilling</b>	Grilling meat and fish with the door closed
<b>Fan assisted</b>	A full cooking function good for roasting and baking
<b>Conventional oven</b>	A full cooking function for roasting and baking in the lower half of the oven
<b>Browning element</b>	To brown and crisp cheese topped dishes
<b>Base heat</b>	To crisp up the bases of quiche, pizza or pastry

Table 2-3

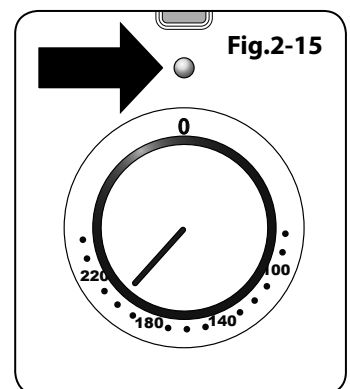
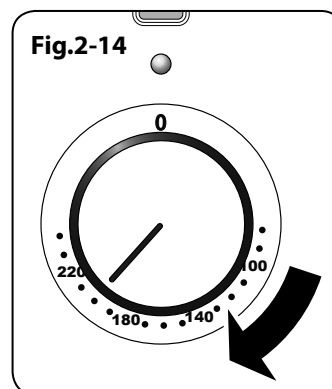
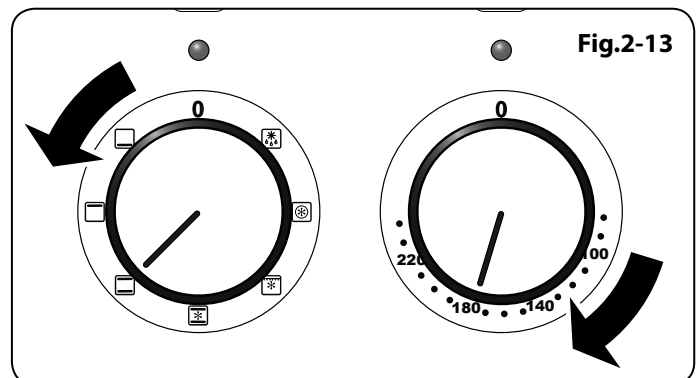
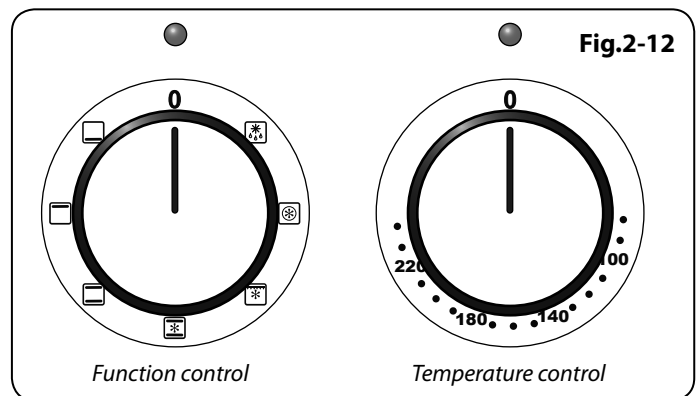

## Accessories

### Oven Shelves

The cooker is supplied with the following:

#### Left-hand oven

- 1 standard shelf (Fig.2-16)
- 1 drop shelf (Fig.2-17)
- 1 telescopic shelf with runners (Fig.2-18)
- 1 set of side supports (Fig.2-19)

#### Right-hand oven

- 4 flat cooking shelves (Fig.2-20)
- 1 plate warming shelf (Fig.2-21)
- 1 set of side supports (Fig.2-22)

#### To remove and refit the shelves

The shelf has a small kink on either side (Fig.2-23). To remove the shelf, line these up with the stops in the shelf support (Fig.2-24). Lift the shelf upwards so that it will pass over the shelf stop and then pull it forwards (Fig.2-25).

Refit in the reverse order, making sure to push it fully back.

#### To remove and refit the telescopic shelf and runners

Slide the shelf out on the runners. While holding one of the runners securely, carefully lift the rear of the shelf upwards: the shelf will spring clear of the central restraining tab. Repeat for the opposite side of the shelf.

**Note:** To aid the removal of the shelf you can insert a suitable flat tool through the opening in the side of the runners and lever the shelf clear (Fig.2-26).

Tilt the front of the shelf downwards and then lift clear of the runners (Fig.2-27).

Refit in the reverse order, making sure to push the shelf down onto the runner arms.

#### To remove and refit the ladder shelf supports

Lift the ladder support hooks out of the two locating holes in the oven side (or divider) before lifting the support clear of the bottom ladder restraint.

Refit by inserting the bottom of the ladder into the restraint before fitting the hooks through the locating holes.

#### Oven shelves – Right-hand (Tall) Oven

When using the tall oven, you can cook on all four shelves at the same time, but make sure that they are well spaced out allow the hot air to circulate.

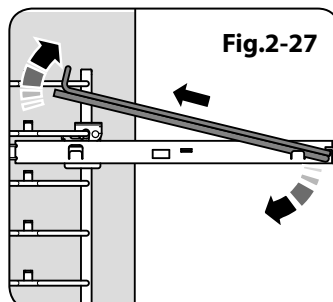
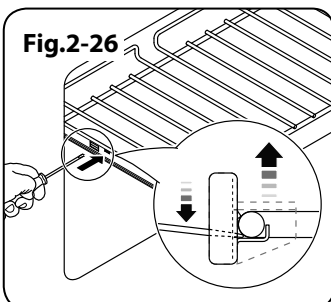
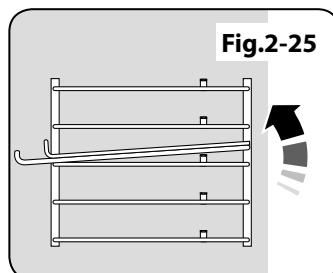
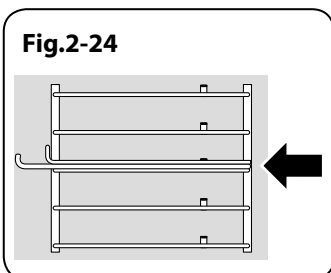
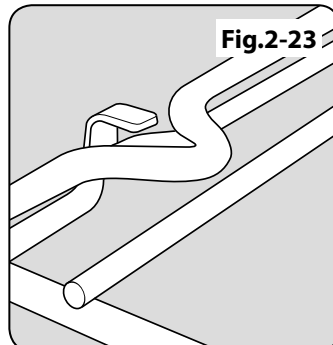
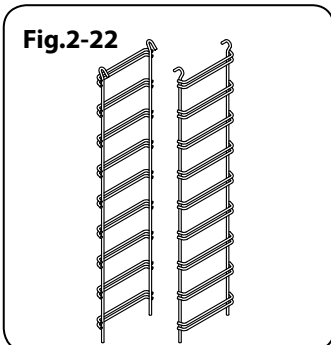
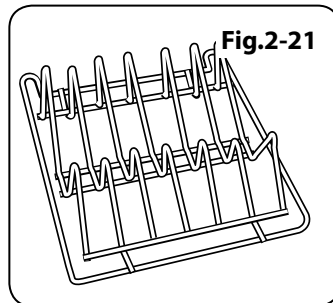
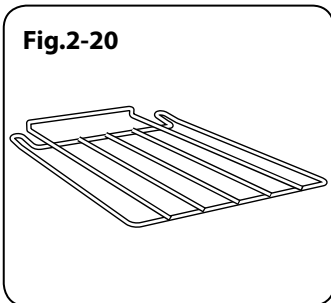
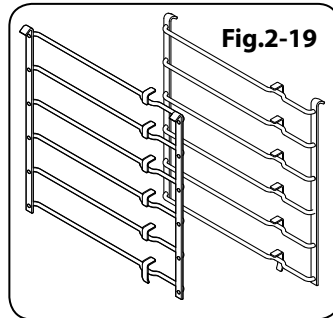
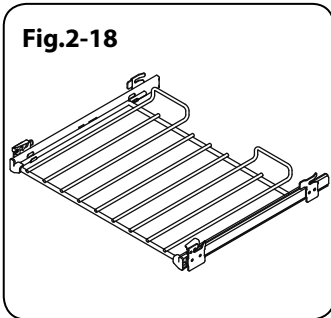
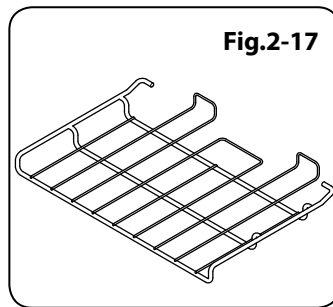
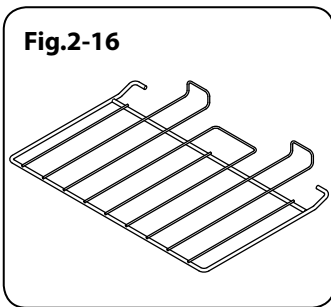

## 3. Cooking Tips

---

### Cooking with a Multi-function Oven

Remember: not all modes are suitable for all food types. The oven cooking times given are intended for a guide only.

### General Oven Tips

The wire shelves should always be pushed firmly to the back of the oven.

*Baking trays with food cooking on them should be placed level with the front edge of the oven's wire shelves. Other containers should be placed centrally. Keep all trays and containers away from the back of the oven, as overbrowning of the food may occur.*

For even browning, the maximum recommended size of a baking tray is 340 mm (13½") by 340 mm (13½") and 232 mm (9 1/8") by 321 mm (12 5/8") in the tall oven.

**When the oven is on, do not leave the door open for longer than necessary, otherwise the knobs may get very hot.**

- Always leave a 'fingers width' between dishes on the same shelf. This allows the heat to circulate freely around them.
- To reduce fat splashing when you add vegetables to hot fat around a roast, dry them thoroughly or brush lightly with cooking oil.
- Where dishes may boil and spill over during cooking, place them on a baking tray.
- Sufficient heat rises out of the oven while cooking to warm plates in the grill compartment.
- If you want to brown the base of a pastry dish, preheat the baking tray for 15 minutes before placing the dish in the centre of the tray.

## 4. Cooking Table

The oven control settings and cooking times given in the table below are intended to be used **AS A GUIDE ONLY**. Individual tastes may require the temperature to be altered to provide a preferred result.

Food is cooked at lower temperature in a fan oven than in a conventional oven. When using recipes, reduce the fan oven temperature by 10 °C and the cooking time by 5-10 minutes. The temperature in the fan oven does not vary with height in the oven so you can use any shelf.

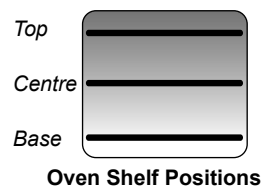

T - top, C - centre, B - base

Food	Conventional Oven	Fan Oven	Approximate cooking time	
	Temperature °C & (Shelf Position)	Temperature °C		
<b>Meat</b>				
Beef (no bone)	160 (C)	150	30-35 minutes per 500g +30-35 minutes.	<i>Thoroughly thaw frozen joints before cooking. Meat may be roasted at 220°C (210°C for fan oven) and the cooking time adjusted accordingly. For stuffed and rolled meats, add approximately 10 minutes per 500g, or cook at 200°C (190°C) for 20 minutes then 160°C (150°C) for the remainder.</i>
	200 (C)	190	20-25 minutes per 500g +20-25 minutes.	
Lamb	160 (C)	150	30-35 minutes per 500g +30-35 minutes.	
	200 (C)	190	25-30 minutes per 500g +25-30 minutes.	
Pork	160 (C)	150	35-40 minutes per 500g +35-40 minutes.	
	200 (C)	190	25-30 minutes per 500g +25-30 minutes.	
<b>Poultry</b>				
Chicken	160 (C)	150	20-25 minutes per 500g +20-25 minutes.	<i>For stuffed poultry, you could cook at 200°C (190°C) for 20 minutes then 160°C (150°C) for remainder. Do not forget to include the weight of the stuffing. For fresh or frozen prepacked poultry, follow instructions on the pack. Thoroughly thaw frozen poultry before cooking.</i>
	200 (C)	190	15-20 minutes per 500g +15-20 minutes.	
Turkey	160 (C)	150	20 minutes per 500g +20 minutes.	
	200 (C)	190	15 minutes per 500g +15 minutes.	
Duck	160 (C)	150	25-30 minutes per 500g.	
	200 (C)	190	20 minutes per 500g.	
<b>Casserole</b>	140-150 (C)	130-140	2-4 hours according to recipe.	
<b>Yorkshire pudding</b>	220 (C)	210	Large tins 30-35 minutes; individual 10-20 minutes.	
<b>Fish</b>				
Fillet	190 (C/B)	180	15-20 minutes.	
Whole	190 (C/B)	180	15-20 minutes per 500g.	
Steak	190 (C/B)	180	Steaks according to thickness.	
<b>Cake</b>				
Very rich fruit - Christmas, wedding, etc.	140 (C/B)	130	45-50 minutes per 500g of mixture.	<i>Using the conventional oven: when two tier cooking leave at least one runner space between shelves. Position the baking tray with the front edge along the front of the oven shelf.</i>
Fruit 180 mm tin	150 (C/B)	140	2-2½ hours.	
Fruit 230 mm tin	150 (C/B)	140	Up to 3½ hours.	
Madeira 180 mm	160 (C/B)	150	80-90 minutes.	<i>Up to three tiers can be cooked in a fan oven at the same time but make sure to leave at least one runner space between each shelf being cooked on.</i>
Queen cakes	190 (C/B)	180	15-25 minutes.	
Scones	220 (C/B)	210	10-15 minutes.	
Victoria sandwich				
180 mm tin	180 (C/B)	170	20-30 minutes.	
210 mm tin	180 (C/B)	170	30-40 minutes.	
<b>Desserts</b>				
Shortcrust tarts	200 (C/B)	190	20-30 minutes on a preheated tray.	<i>Using the conventional oven: for even browning the maximum size of baking tray recommended is 340 mm x 340 mm. This ensures free heat circulation. If cooking a two tier load, the trays should be interchanged approximately halfway through the cooking time.</i>
Fruit pies	200 (C/B)	190	35-45 minutes.	
Tartlets	200 (C/B)	190	10-20 minutes according to size.	
Puff pastry	230 (C/B)	220	20-40 minutes according to size.	
Meringues	100 (C/B)	90	2-3 hours.	
Baked egg custard	160 (C/B)	150	45-60 minutes.	
Baked sponge pudding	190 (C/B)	180	40-45 minutes.	
Milk pudding	140-150 (C/B)	130-140	2 to 3 hours.	
<b>Bread</b>	220 (C)	210	20-30 minutes.	

## 5. Cleaning Your Cooker

Isolate the electricity supply before carrying out any major cleaning. Allow the cooker to cool.

**Never use paint solvents, washing soda, caustic cleaners, biological powders, bleach, chlorine based bleach cleaners, coarse abrasives or salt. Do not mix different cleaning products – they may react together with hazardous results.**

All parts of the cooker can be cleaned with hot soapy water – **but take care that no surplus water seeps into the appliance.**

Remember to switch the electricity supply back on before reusing the cooker.

### Hob

#### Daily Care

First of all make sure that all heat indicator lights are off and that the cooking surface is cool. Apply a small dab of ceramic cleaning cream in the centre of each area to be cleaned. Dampen a clean paper towel and work the cream onto the cooking surface. As a final step, wipe the cooking surface with a clean, dry paper towel.

#### Cleaning Spills

For spills and boil-overs that occur while cooking, turn the unit off and wipe the area surrounding the hot zone with a clean paper towel. If a spill (other than a sugary substance) is on the hot zone, do not clean until the unit has completely cooled down, and then follow the instructions below (*'Cleaning burned-on spills'*).

If you accidentally melt anything on the surface, or if you spill foods with a high sugar content (preserves, tomato sauce, fruit juice, etc.), remove the spill **IMMEDIATELY** with a razor scraper, while the unit is still hot.

**IMPORTANT: Use an oven glove to protect your hand from potential burns.**

Scrape the major spill or melted material from the cooking zone and push into a cold area. Then, turn the unit 'OFF' and allow it to cool before cleaning further. After the cooking surface cools down and the heat indicator lights go off, follow the *'Daily Care'* procedure outlined above.

#### Cleaning Burned-on Spills

Make sure that the heat indicator lights are off and that the hob is cool. Remove the excess burned-on substance with a single-edged razor scraper. Hold the scraper at an angle of about 30° to the surface and then scrape off the burned-on matter (**Fig.5-1**).

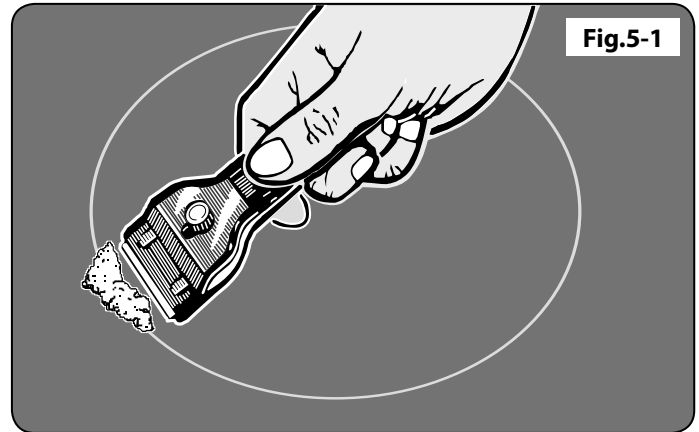

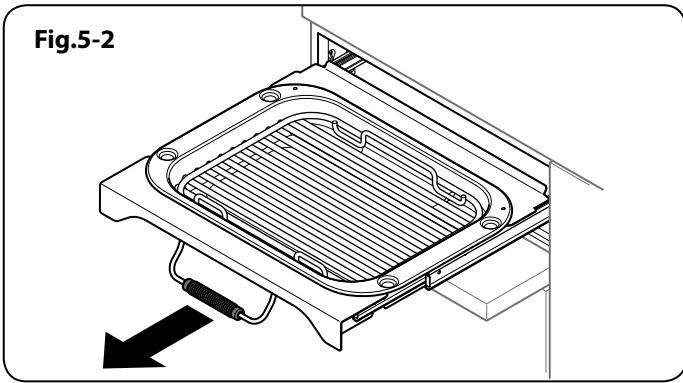

Fig.5-2

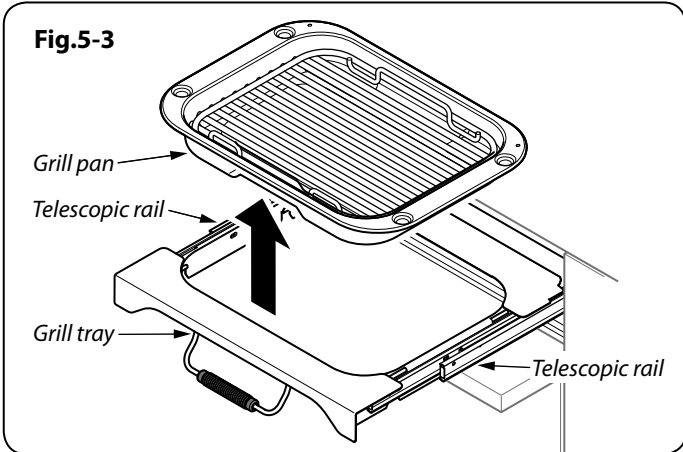

Fig.5-3

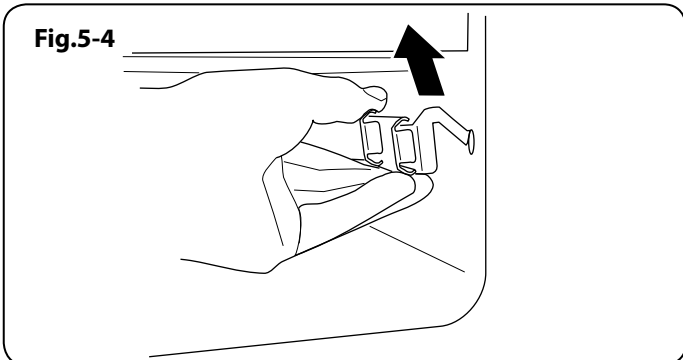

Fig.5-4

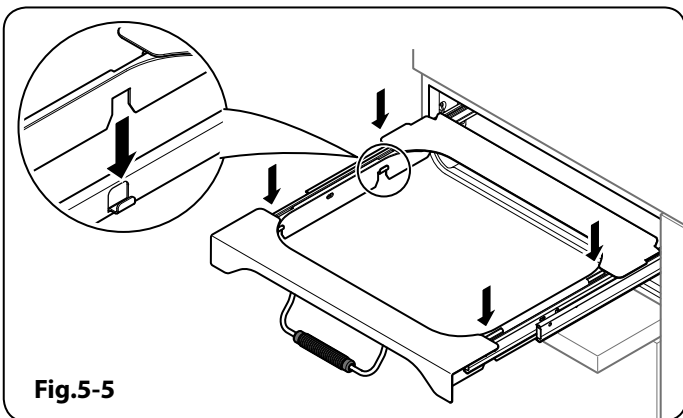

Fig.5-5

## Glide-out Grill

**⚠ Before you remove any of the grill parts for cleaning, make sure that they are cool, or use oven gloves.**

The grill pan and grill tray assembly can be easily removed for cleaning.

Wash the grill pan and trivet washed in hot soapy water, or using our recommended Rangemaster cleaning solution.

After grilling meats or any foods that soil, leave to soak for a few minutes in the sink immediately after use. Stubborn particles may be removed from the trivet by using a nylon brush.

Alternatively, wash the grill pan in a dishwasher.

To remove the grill pan pull the tray assembly forwards (**Fig.5-2**) and then lift the grill pan clear of the grill tray assembly (**Fig.5-3**).

For safety, push the grill tray back into the grill chamber.

If you need to remove the telescopic runners to allow cleaning of the grill chamber, first remove the grill tray then you can unhook them from the grill chamber sides (**Fig.5-4**).

Wipe the sides clean with a soft cloth and mild detergent.

**DO NOT put the side runners in a dishwasher.**

Once you have finished, hook the side rails back onto the sides of the chamber. Pull the telescopic rails out and fit the grill tray onto them, making sure to locate the cut-outs onto the telescopic runner tabs (**Fig.5-5**).

Replace the grill pan.

## Control Panel and Oven Doors

Avoid using any abrasive cleaners including cream cleaners, on brushed stainless steel surfaces. For best results, use a liquid detergent.

The control panel and control knobs should only be cleaned with a soft cloth wrung out in clean hot soapy water – but take care that no surplus water seeps into the appliance. Wipe with a clean dampened cloth then polish with a dry cloth.

The oven doors should only be cleaned with a soft cloth wrung out in clean hot soapy water.

## Ovens

### Base Tray

The ovens have a removable base tray, which can be easily removed for cleaning.

Wash the base tray with a proprietary enamel cleaner, or using our recommended Rangemaster cleaning solution. Alternatively, wash the base tray in a dishwasher.

### 'Cook & Clean' Panels

The ovens have side 'Cook & Clean' panels which have been coated with a special enamel that partly cleans itself. This does not stop all marks on the lining, but helps to reduce the amount of manual cleaning needed.

These panels work better above 200°C. If you do most of your cooking below this temperature, occasionally remove the panels and wipe with a lint free cloth and hot soapy water. The panels should then be dried and replaced and the oven heated at 200°C for about one hour. This will make sure that the panels are working effectively.

**⚠ DO NOT use steel wool (or any other materials that will scratch the surface).**

**⚠ DO NOT use oven cleaning pads.**

### The Oven Shelf Supports

The shelf supports on the oven sides can be removed for cleaning.

#### **To remove and refit the telescopic shelf and runners**

Slide the shelf out on the runners. While holding one of the runners securely, carefully lift the rear of the shelf upwards: the shelf will spring clear of the central restraining tab. Repeat for the opposite side of the shelf.

**Note:** To aid the removal of the shelf you can insert a suitable flat tool through the opening in the side of the runners and lever the shelf clear (**Fig.5-6**).

Tilt the front of the shelf downwards and then lift clear of the runners (**Fig.5-7**).

Refit in the reverse order, making sure to push the shelf down onto the runner arms.

#### **Removing the oven shelf supports**

Remove the oven shelves. Pull the top of the shelf support up and away from the oven side and then lift the support away from the locating bracket at the bottom of the oven side (**Fig.5-8**).

#### **Refitting the oven shelf supports**

To refit the side support. Locate the tag at the bottom of the support into the slot in the locating bracket in the oven side (**Fig.5-9**). Now locate the tops of the side arms in the holes at the top and gently push down.

### The Tall Oven

To clean the oven sides, slide out the shelves, unhook the supports from the oven sides and lift out (**Fig.5-10**).

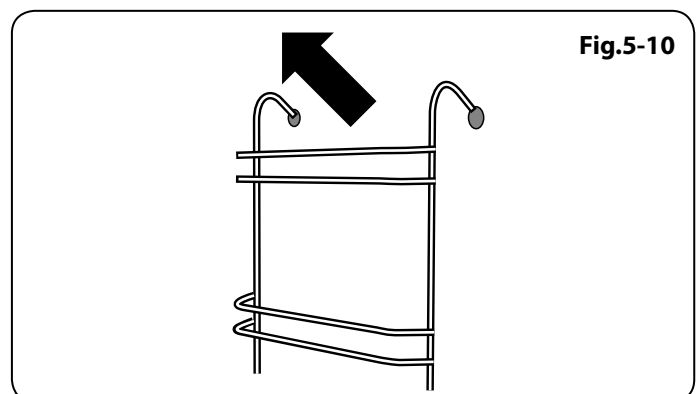
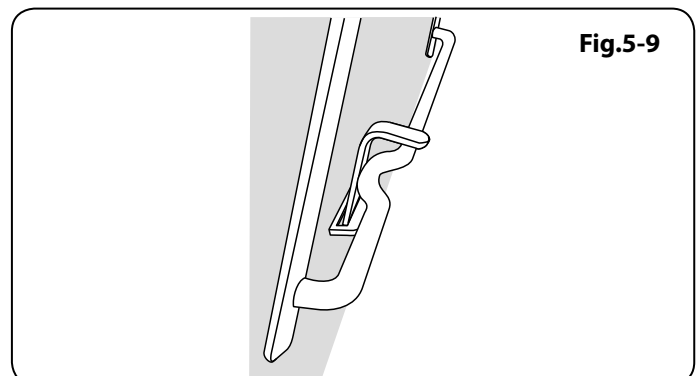
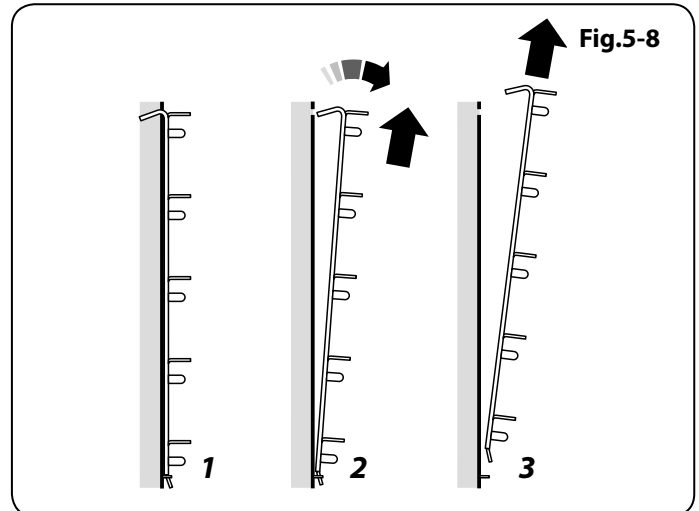
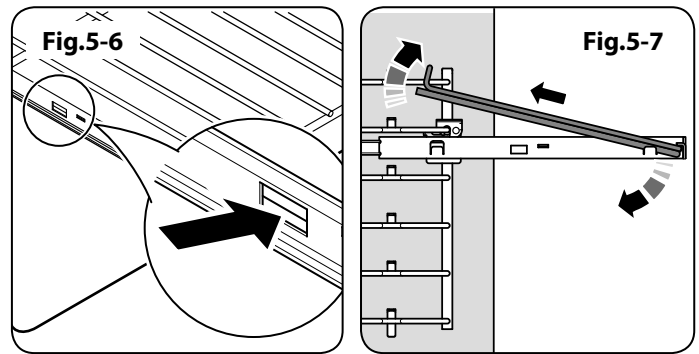

## Cleaning Table

Cleaners listed (**Table 5-1**) are available from supermarkets or electrical retailers as stated.

For enamelled surfaces use a cleaner that is approved for use on vitreous enamel.

Regular cleaning is recommended. For easier cleaning, wipe up any spillages immediately.

<b>Hotplate</b>		
<b>Part</b>	<b>Finish</b>	<b>Recommended Cleaning Method</b>
Hob Top	Enamel or stainless steel	Hot soapy water, soft cloth. Any stubborn stains remove gently with a nylon scourer.
Ceramic/Induction hob	Toughened glass	Hot soapy water; cream cleaner/scourer if necessary.
Griddle plate (some models only)	Non-stick surface	Allow to cool. Wash in hot soapy water. Do not use abrasive cleaners/scourers. Dishwasher.
Warming zone (some models only)	Toughened glass	Hot soapy water, cream cleaner/scourer if necessary.
<b>Outside of cooker</b>		
<b>Part</b>	<b>Finish</b>	<b>Recommended Cleaning Method</b>
Door, Door surround and Storage drawer exterior.	Enamel or paint	Hot soapy water, soft cloth. Any stubborn stains, remove gently with a liquid detergent.
	Stainless steel	E Cloth ( <i>electrical retailer</i> ) or Microfibre all-purpose cloth ( <i>supermarket</i> ).
Sides and plinth	Painted surface	Hot soapy water, soft cloth.
Splashback/rear grille	Enamel or stainless steel	Hot soapy water, soft cloth. Cream cleaner, with care, if necessary.
Control panel	Paint, enamel or stainless steel	Warm soapy water. Do not use abrasive cleaners on lettering.
Control knobs/handles & trims	Plastic/chrome, aluminium, copper or lacquered brass	Warm soapy water, soft cloth.
	Brass	Brass polish.
Oven door glass/Glass lid	Toughened glass	Hot soapy water, cream cleaner/scourer if necessary.
<b>Oven and Grill</b>		
<b>Part</b>	<b>Finish</b>	<b>Recommended Cleaning Method</b>
Sides, floor & roof of oven <b>NOT</b> COOK & CLEAN OVEN PANELS (see below)	Enamel	Any proprietary oven cleaner that is suitable for enamel. <b>CAUTION: CORROSIVE/CAUSTIC OVEN CLEANERS: FOLLOW MANUFACTURER'S INSTRUCTIONS.</b> Do not allow contact with the oven elements.
Cook & Clean oven panels (some models only)	Special enamel that partly cleans itself	This surface cleans itself at 200°C and above, or the panels can be removed and washed with hot soapy water and a nylon brush (see 'The Ovens' in 'Cleaning your cooker').
Oven shelves, Handyrack, Grill trivet, Handygrill rack	Chrome	An oven interior cleaner that is suitable for chrome. Soap filled pad. Dishwasher.
Grill pan/Meat tin (some models only)	Enamel	Hot soapy water. Soap filled pad. Dishwasher.

**Table 5-1**

## 6. Troubleshooting

---

**⚠ Interference with and repairs to the hob MUST NOT be carried out by unqualified persons. Do not try to repair the hob as this may result in injury and damage to the hob. Please arrange for repair by a suitably competent person.**

**Note:** The induction hob is able to self-diagnose a number of problems and can show this information to the user via the hob control display. Error codes may be displayed if your hob has developed a fault.

If your appliance reports an error or is not working, you may be able to correct the fault by consulting the following.

### **Error code E2 is displayed**

The electronic unit is too hot. Please check the installation of the cooker, making sure that there is sufficient ventilation. In extreme cases, if a cooking utensil has been allowed to boil dry this error code may also be displayed. If in doubt please contact your installer or a qualified repair engineer.

### **No display operation**

Over voltage or loss of supply voltage to the cooker. If in doubt please contact your installer or a qualified repair engineer.

### **Error code U400 is displayed**

The hob/range has been incorrectly connected. The control will switch off after approximately 1 second and the error code will be permanently displayed.

Consult your installer or a qualified repair engineer.

### **Error code Er followed by a number is displayed**

The appliance has developed an internal technical fault that cannot be rectified by the user.

Consult your installer or a qualified repair engineer

### **The fuse blows or the RCD trips regularly**

Please contact your installer or a qualified repair engineer.

### **The hob will not switch on**

Has the wiring system in the house blown a fuse or tripped an RCD?

Has the hob been correctly connected to the mains supply?

Has the child lock been activated? Please refer to the child lock section for details of this function.

### **The induction hob is noisy**

When using the induction hob there may be some 'noise' emitted from the pan. This is normal and may be most noticeable when cooking on high power settings or if 5 pans are used simultaneously. The type of pan may also contribute to induction 'noise'.

### **The cooling fan**

The induction hob incorporates a cooling fan. This cooling fan is active when the cooker is in use. Under certain conditions, the cooling fan may remain active when the cooker is switched off. This is normal and the fan will switch off automatically.

### **The fascia gets hot when I use the oven or grill**

If the fascia becomes excessively hot when the cooker is in use then the cooling fan may have failed. Should this occur please contact your installer, a qualified repair engineer or Customer Service to arrange for its repair.

### **A crack has appeared in the hob surface**

Disconnect the cooker immediately from the power supply and arrange for its repair. Do not use the cooker until after the repair.

### **My hob is scratched**

Always use the cleaning methods recommended in this guide, and ensure that the pan bottoms are smooth and clean.

Marks from mineral deposits from water or food can be removed with a cleaning cream. However, tiny scratches are not removable but will become less visible in time as a result of cleaning.

### **The oven fan is noisy**

The sound of the oven fan may change as the oven heats up – this is perfectly normal.

### **Grill not cooking properly**

Are you using the pan and trivet supplied with the cooker? Is the pan being used on the runners, not the floor of the compartment? Is the grill tray pushed back fully to the 'back stop' position?

### **The knobs get hot when I use the oven or grill. Can I avoid this?**

Yes, this is caused by heat rising from the oven or the grill, and heating them up. Do not leave the oven door open. Make sure that the grill pan is pushed right back to the 'back stop' when grilling.

Always grill with the grill compartment door open.

**If there is an installation problem and I don't get my original installer to come back to fix it, who pays?**

You do. Service organisations will charge for their call-outs if they are correcting work carried out by your original installer. Therefore, it's in your own interest to keep track of this installer so that you can contact them as required.

**Food is cooking too slowly, too quickly, or burning**

Cooking times may differ from your previous oven. Check that you are using the recommended temperatures and shelf positions – see the oven cooking guide. You can then adjust the settings according to your own individual tastes.

**Oven temperature getting hotter as the cooker gets older**

If turning the temperature down using the oven control knob has not worked, or has only worked for a short time, then you may need a new thermostat. This should be fitted by a service person.

**The oven is not cooking evenly**

Do not use a baking tray with dimensions larger than those specified in the section on 'General Oven Tips'.

If you are cooking a large item, be prepared to turn it round during cooking.

If two shelves are used, check that space has been left for the heat to circulate. When a baking tray is put into the oven, make sure that it is placed centrally on the shelf.

Check that the door seal is not damaged and that the door catch is adjusted so that the door is held firmly against the seal.

A dish of water when placed on the shelf should be the same depth all over. (For example, if it is deeper at the back, then the back of the cooker should be raised up or the front lowered.) If the cooker is not level, arrange for your supplier to level it for you.

## INSTALLATION

**Check the appliance is electrically safe when you have finished.**

# 7. Installation

## Dear Installer

Before you start your installation, please complete the details below, so that, if your customer has a problem relating to your installation, they will be able to contact you easily.

<b>Installer's Name</b>
<b>Installer's Company</b>
<b>Installer's Telephone number</b>
<b>Appliance Serial Number</b>

## Safety Requirements and Regulations

You must be aware of the following safety requirements & regulations.

- ⚠ This cooker must be installed in accordance with the relevant instructions in this booklet, with the relevant national and local regulations, and with the local electricity supply companies' requirements.**
- ⚠ The appliance must be installed in accordance with the regulations in force and only in a well-ventilated space.**
- ⚠ Read the instructions before installing or using this appliance.**
- ⚠ This appliance is designed for domestic cooking only. Use for any other purpose could invalidate any warranty or liability claim.**

## Provision of Ventilation

This appliance is not connected to a combustion products evacuation device. Therefore, particular attention must be given to the relevant requirements regarding ventilation.

All rooms require a window that can be opened, or equivalent, while some rooms require a permanent vent in addition to the window.

## Location of Cooker

The cooker may be installed in a kitchen/kitchen diner but NOT in a room containing a bath or shower.



**You will need the following equipment to complete the cooker installation satisfactorily:**

- Multimeter (for electrical checks)
- Allen keys (provided in pack)

**You will also need the following tools:**

1. Steel tape measure
2. Cross-head screwdriver
3. Flat head screwdriver
4. Spirit level
5. 13 mm spanner or socket wrench

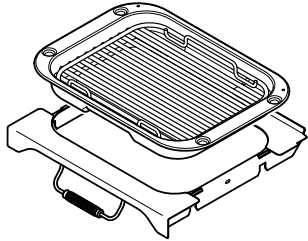
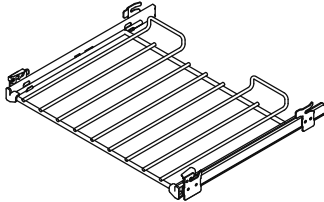
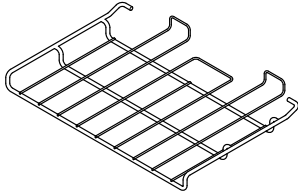
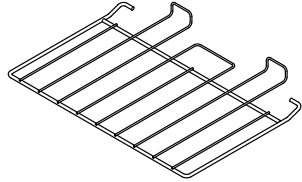
**Checking the Parts:**

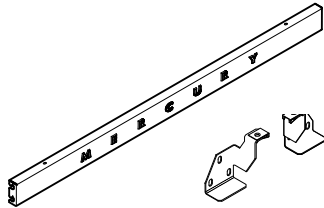
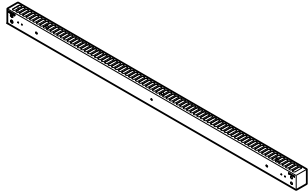
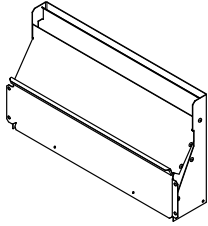
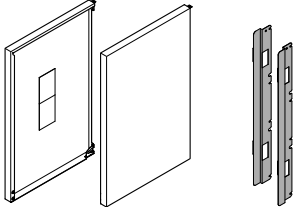
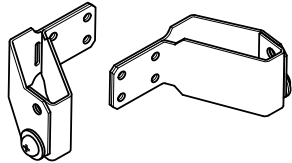
<i>Grill pan, trivet &amp; cradle</i>	<i>1 telescopic shelf</i>
	
<i>1 drop shelf</i>	<i>1 flat shelf</i>
	
<i>Tall oven shelves &amp; supports</i>	<i>Bottom panel &amp; mounting brackets</i>
	
<i>Flue trim</i>	<i>Flue vent</i>
	
<i>Side panels &amp; obscuring trims</i>	<i>Side panel mounting brackets</i>
	

## INSTALLATION

Check the appliance is electrically safe when you have finished.

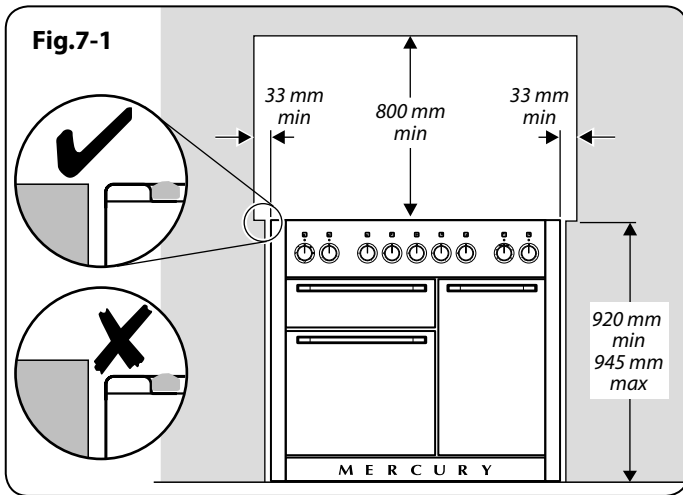

### Positioning the Cooker

**Fig.7-1** shows the minimum recommended distance from the cooker to nearby surfaces.

The cooker should not be placed on a base.

Above hotplate surround should be level with, or above, any adjacent work surface.

A gap of 33 mm should be left between each side of the cooker **ABOVE** the hotplate level and any adjacent vertical surface.

For non-combustible surfaces (such as unpainted metal or ceramic tiles) this gap is not required.

A minimum space of 800 mm is required between the top of the hotplate and a horizontal combustible surface.

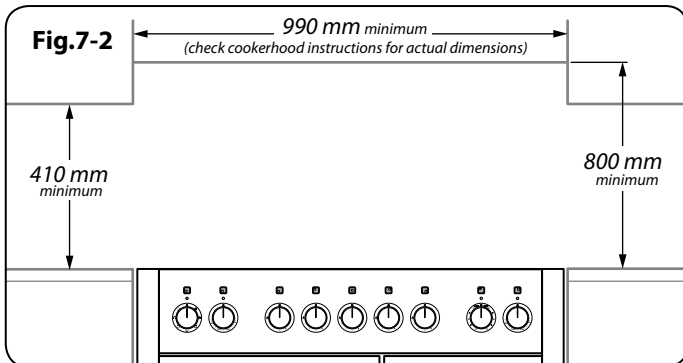
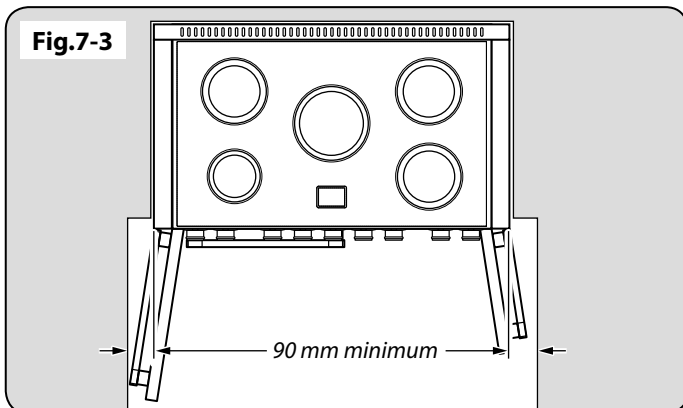

**Fig.7-2** shows the suggested clearances above the cooker.

**\* Any cookerhood should be installed in accordance with the hood manufacturer's instructions.**

Surfaces of furniture and walls at the sides and rear of the appliance should be heat, splash and steam resistant. Certain types of vinyl or laminate kitchen furniture are particularly prone to heat damage and discolouration.

We cannot accept responsibility for damage caused by normal use of the cooker to any material that de-laminates or discolours at temperatures less than 65 °C above room temperature.



We recommend a gap of 1000 mm between units to allow for moving the cooker. Do not box the cooker in – it must be possible to move the cooker in and out for cleaning and servicing.

A clearance of 90 mm is required if the cooker is near a corner of the kitchen to allow the oven doors to open (**Fig.7-3**). The actual opening of the doors is slightly less but this allows for some protection of your hand as you open the door.

### Moving the Cooker

**⚠ On no account try and move the cooker while it is plugged into the electricity supply.**

**⚠ The cooker is very heavy, so take great care.**

We recommend that two people manoeuvre the cooker. Make sure that the floor covering is firmly fixed, or removed, to prevent it being disturbed when moving the cooker around.

To help you, there are two levelling rollers at the back, and two screw-down levelling feet at the front.

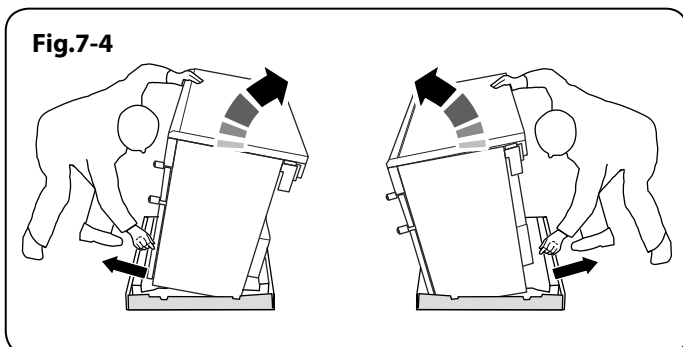

Remove the polystyrene base pack. From the front, tilt the cooker forward and remove the front half of the polystyrene base (**Fig.7-4**). Repeat from the back and remove the rear half of the polystyrene base.

## INSTALLATION

Check the appliance is electrically safe when you have finished.

### Lowering the Two Rear Rollers

To adjust the height of the rear of the cooker, first fit a 13 mm spanner or socket wrench onto the hexagonal adjusting nut (**Fig.7-5**). Rotate the nut – clockwise to raise – counter-clockwise to lower.

Make 10 complete (360°) turns clockwise.

Make sure you lower BOTH REAR ROLLERS.

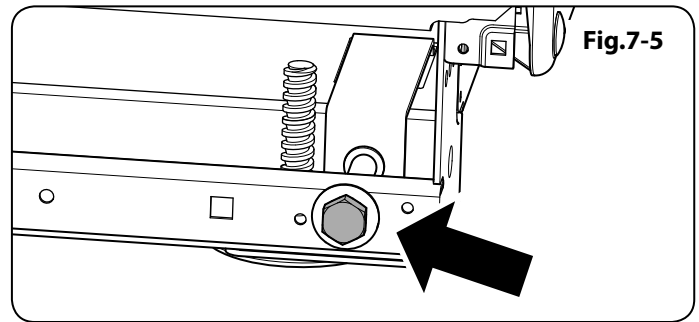

### Completing the Move

Unfold the rear edge of the pack base tray. Open the grill door and right-hand oven door so that you can get a good grip on the bottom of the fascia panel as you move the oven (**Fig.7-6**).

Carefully push the cooker backwards off the pack base. Remove the pack base tray.

Position the cooker close to its final position, leaving just enough space to get behind it.

**⚠ DO NOT use the door handles or control knobs to manoeuvre the cooker.**

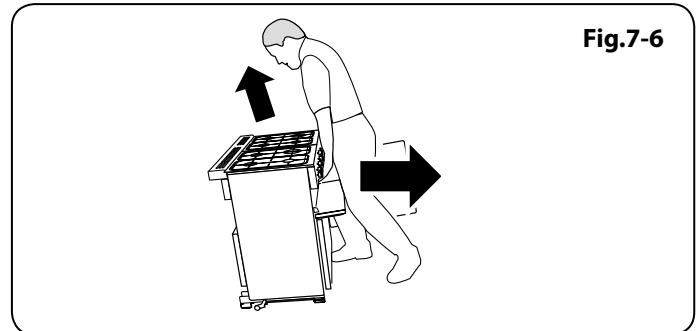

### Fitting the Flue and Vent

#### Fitting the Flue

Remove the four screws from the grill flue opening.

Offer the removable flue up to grill flue opening. Making sure that the removable flue bottom flange fits inside the fixed flue, secure in place with the four screws (**Fig.7-7**).

#### Fitting the Flue Vent

Loosen the three screws in the back of the hotplate. Fit the flue vent over the screws and slide down (**Fig.7-8**). Tighten the screws to secure.

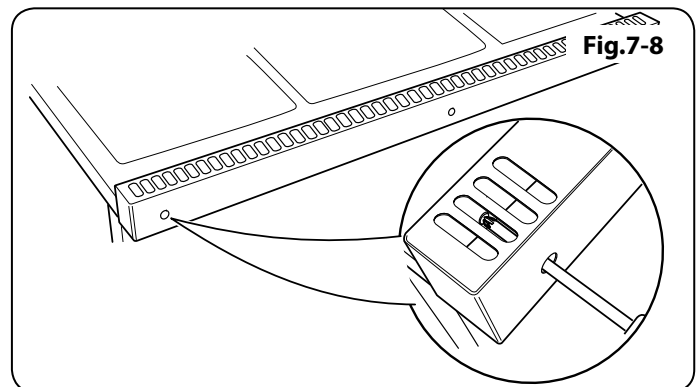
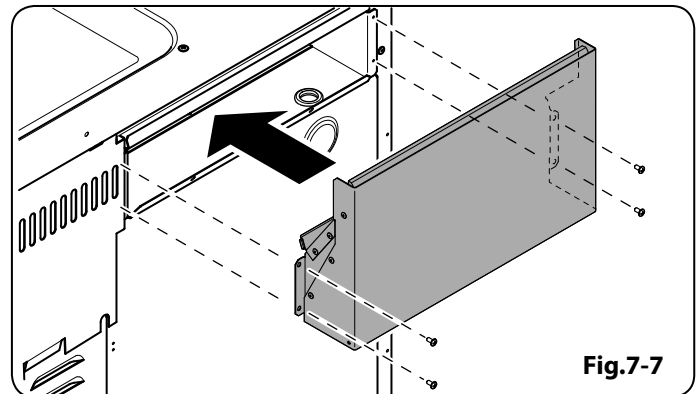

## INSTALLATION

Check the appliance is electrically safe when you have finished.

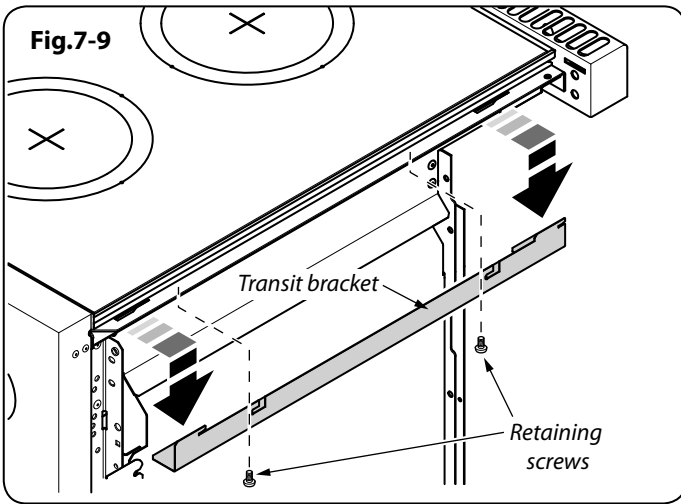

### Fitting the Side Panel and Obscuring Trims

**IMPORTANT:** Before fitting the side panels you must first remove the transit brackets. Loosen the two screws in the underside of the transit bracket (**Fig.7-9**). Slide the bracket forwards and remove.

### Fitting the Obscuring Trims

Located near the front on each side of the cooker there are three screws – loosen the top and bottom screws (**Fig.7-10**). Slide the trim onto the screws and tighten to secure.

### Fitting the Side Panels

Fit the two side panel retaining brackets onto the rear of the cooker (**Fig.7-11**) and secure.

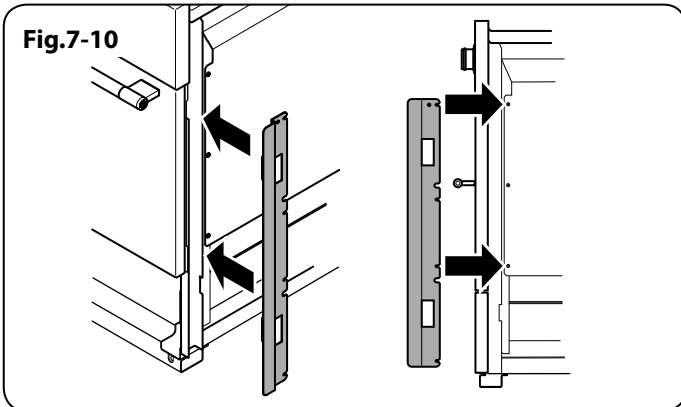

Inside the top of the side panel top are two tabs. Locate these tabs into the cut-outs in the top edge of the cooker (**Fig.7-12**).

Slide the side panel back so that the slot in the base locates onto the washer on the rear retaining bracket (**Fig.7-13**), and the slotted tab at the top rear locates onto the screw in the flue vent.

Push back the side panel so that it touches the rear flue. Tighten the screw in the vent to secure the side panel in position (**Fig.7-14**).

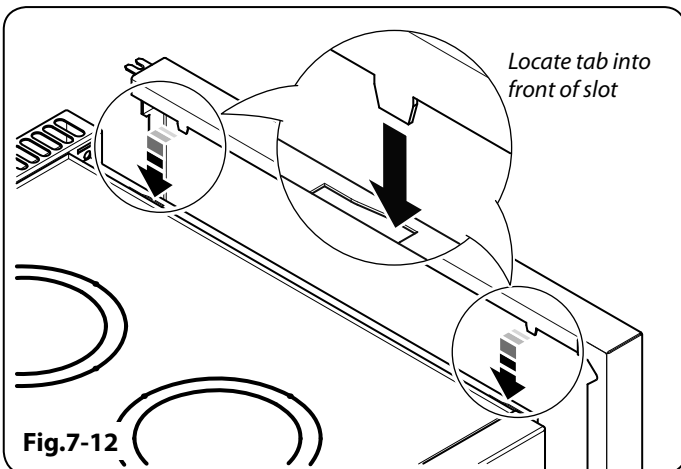
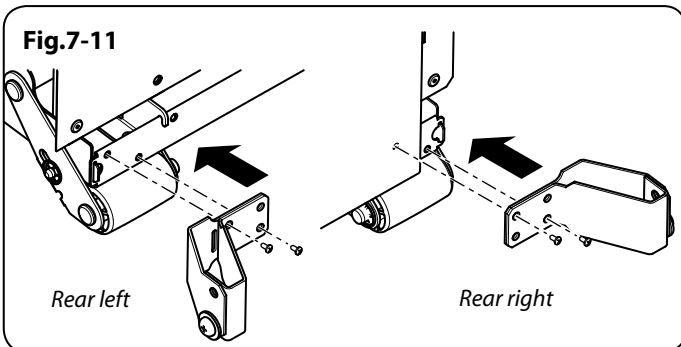

## INSTALLATION

Check the appliance is electrically safe when you have finished.

### Repositioning the Cooker following Connection

If you need to move the cooker once it has been connected then you need to unplug it and, having gripped under the fascia panel and lifted the front of the cooker slightly (**Fig.7-6**), you need to check behind the cooker to make sure that the electricity cable is not caught.

As you progress, make sure that the electricity cable always has sufficient slack to allow the cooker to move.

When you replace the cooker, again check behind to make sure that the electricity cable is not caught or trapped.

### Levelling

You are recommended to use a spirit level on a shelf in one of the ovens to check for level.

Place the cooker in its intended position taking care not to twist it within the gap between the kitchen units as damage may occur to the cooker or the units.

The front feet and rear rollers can be adjusted to level the cooker. To adjust the height of the rear of the cooker use the levelling tool supplied to turn the adjusting nuts at the front bottom corners of the cooker. To set the front, turn the feet bases to raise or lower.

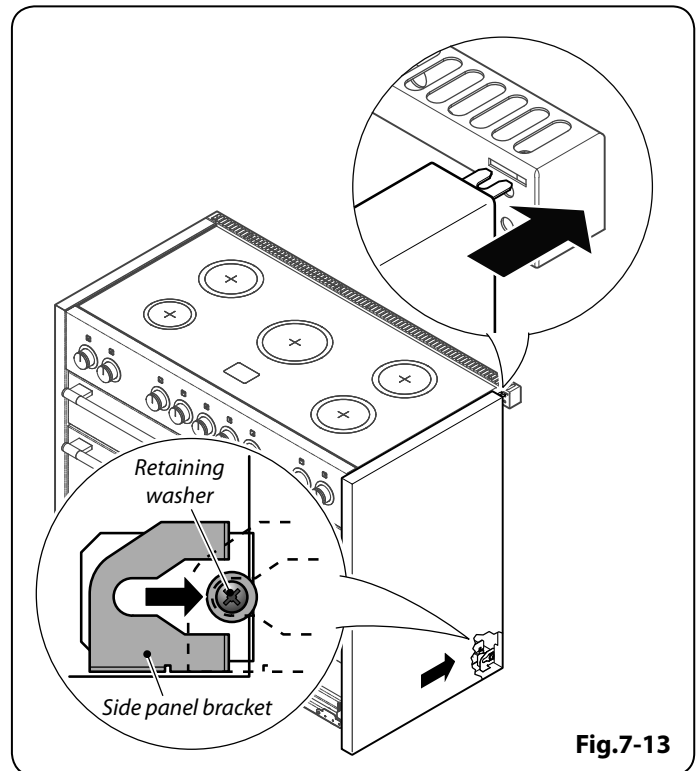

Fig.7-13

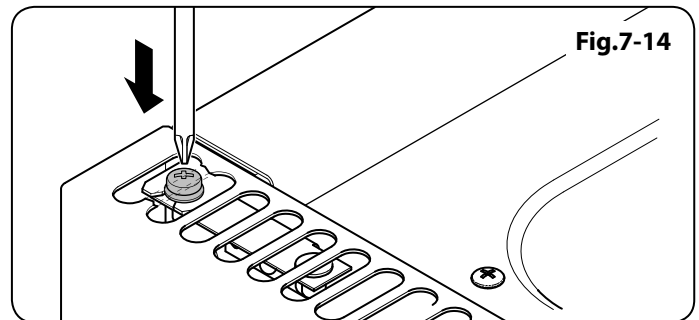

Fig.7-14

## INSTALLATION

Check the appliance is electrically safe when you have finished.

Fig.7-15

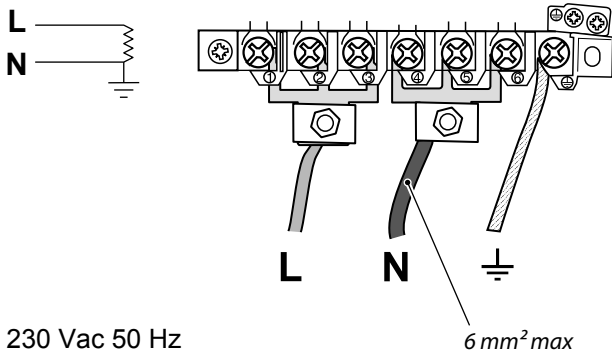
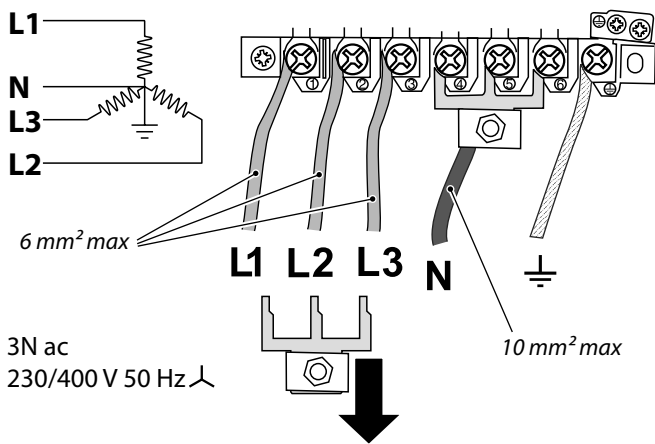

Fig.7-16



## Electrical Connection

The cooker must be installed by a qualified electrician, in accordance with all relevant British Standards/Codes of Practice (in particular BS 7671), or with the relevant national and local regulations.

### Current Operated Earth Leakage Breakers

The combined use of your cooker and other domestic appliances may cause nuisance tripping, so we recommend that the cooker is protected on an individual RCD (Residual Current Device) or RCBO (Residual Current Breaker with Overload).

**IF IN DOUBT, PLEASE CONSULT A SUITABLY QUALIFIED ELECTRICIAN.**

**Note:** The cooker must be connected to the correct electrical supply as stated on the voltage label on the cooker, through a suitable cooker control unit incorporating a double pole switch, having a contact separation of at least 3 mm in all poles.

The cooker must not be connected to an ordinary domestic power point.

Access to the mains terminal is gained by removing the electrical terminal cover box on the back panel. Connect the mains cable to the correct terminals for your electrical supply type (**Fig.7-16** and **Fig.7-17**). Check that the links are correctly fitted and that the terminal screws are tight. Secure the mains cable using the cable clamp.

## Final Checks

### Hotplate Check

Check each cooking zone in turn. Be sure to use pans of the correct size and material.

### Grill Check

Turn on the grill control and check that the grill heats up.

### Oven Check

Turn on the ovens – check that the oven fans start to turn and that the ovens start to heat up.

## INSTALLATION

Check the appliance is electrically safe when you have finished.

### Final Fitting

#### Fitting the Bottom Panel

Open the oven doors.

On the front of the cooker base there are two mounting plates. Remove the three fixing screws from each plate.

Fit the retaining brackets to the mounting plates and refit the screws (**Fig.7-17**). DO NOT tighten at this stage.

Tilt the bottom of the panel slightly to locate the lower slots onto the washers (**Fig.7-18**). Now rotate the panel to fit over the pins (**Fig.7-19**).

Using the two screws supplied, secure the bottom panel onto the brackets. DO NOT tighten at this stage.

Adjust the bottom panel to align it with the door panels. When it is positioned correctly, use a suitable flat open ended spanner to tighten the bracket screws, and then tighten the bottom panel screws.

#### Customer Care

**Installer:** Please complete your details in this Guide, inform the user how to operate the cooker and hand over the instructions.

**Thank you.**

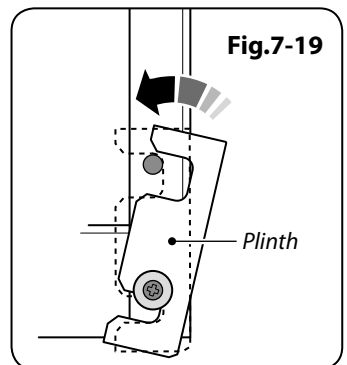
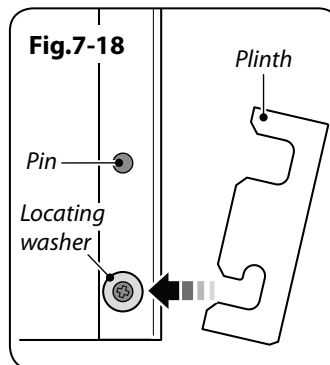
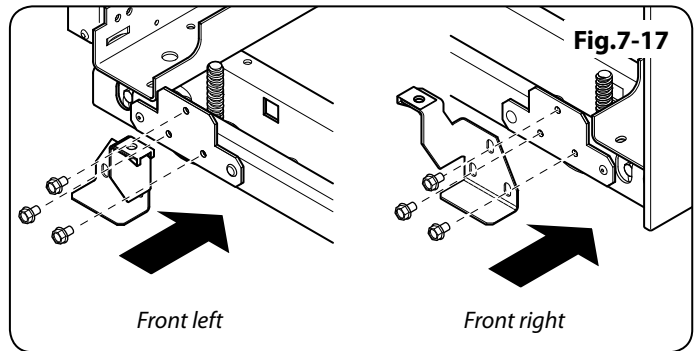

# 8. Circuit Diagrams

## Circuit Diagram: Hob

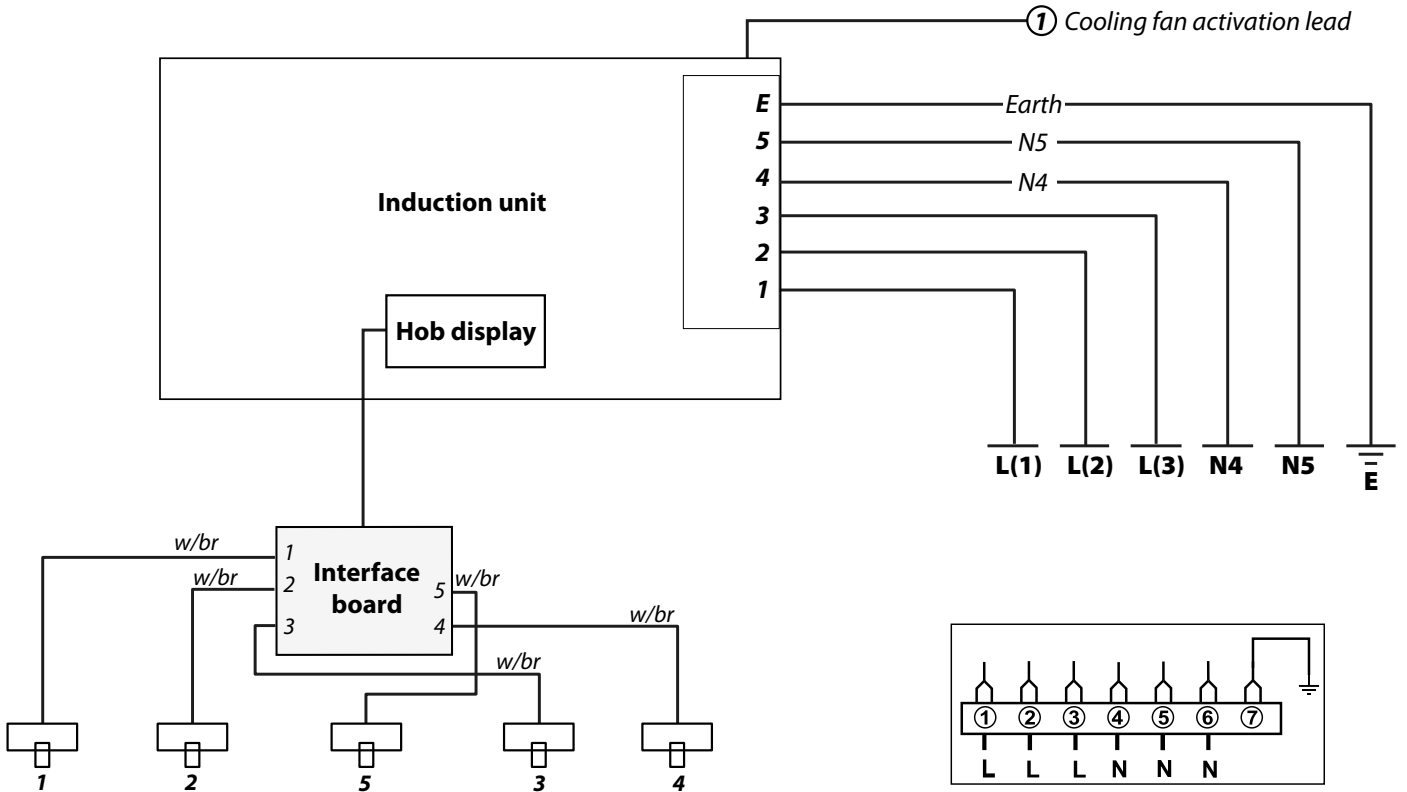

Code	Description
1	Left-hand front element
2	Left-hand back element
3	Right-hand back element
4	Right-hand front element
5	Centre element

Code	Colour
w/br	White or brown

## Circuit Diagram: Ovens

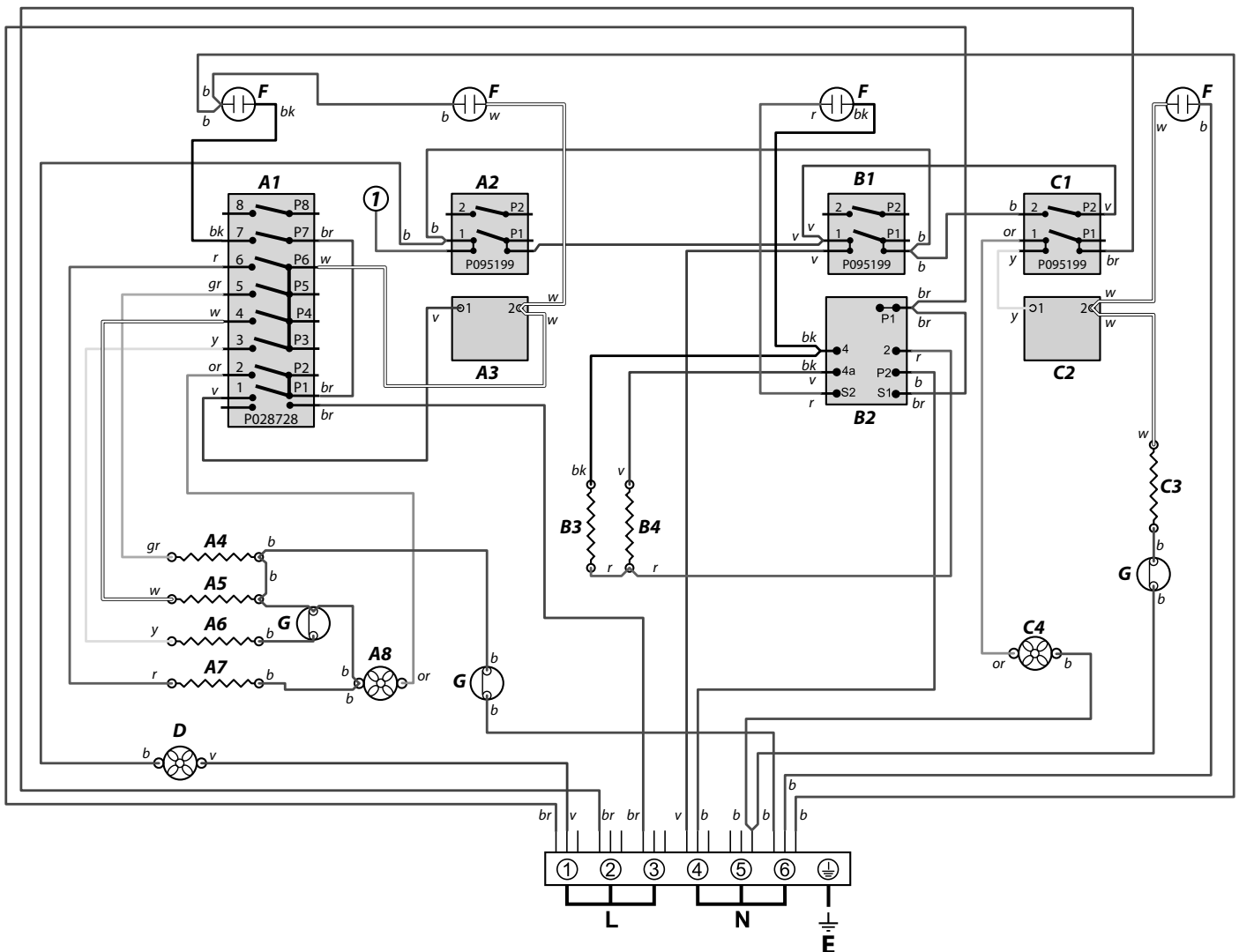

### Key

The connections shown in the circuit diagram are for single-phase. The ratings are for 230 V 50 Hz.

Code	Description
<b>A1</b>	Left-hand MF oven control
<b>A2</b>	Left-hand MF oven control switch
<b>A3</b>	Left-hand MF oven thermostat
<b>A4</b>	Left-hand MF oven top element (outer pair)
<b>A5</b>	Left-hand MF oven browning element (inner pair)
<b>A6</b>	Left-hand MF oven fan element
<b>A7</b>	Left-hand MF oven base element
<b>A8</b>	Left-hand MF oven fan

Code	Description
<b>C1</b>	Right-hand fan oven control switch
<b>C2</b>	Right-hand fan oven thermostat
<b>C3</b>	Right-hand fan oven element
<b>C4</b>	Right-hand oven fan
<b>D</b>	Cooling fan
<b>F</b>	Neon
<b>G</b>	Thermal cut-out

Code	Colour
<b>b</b>	Blue
<b>br</b>	Brown
<b>bk</b>	Black
<b>or</b>	Orange
<b>r</b>	Red
<b>v</b>	Violet
<b>w</b>	White
<b>y</b>	Yellow
<b>g/y</b>	Green/yellow
<b>gr</b>	Grey

## 9. Technical Data

**INSTALLER:** Please leave these instructions with the User.

**DATA BADGE LOCATION :** Cooker back, serial number repeater badge below oven door opening.

**COUNTRY OF DESTINATION:** GB/IE

### Connections

Electric	230/400V 50 Hz
----------	----------------

### Dimensions

Overall height	minimum 920 mm	maximum 945 mm
Overall width	990 mm	
Overall depth	638 mm to front of fascia; 700 mm over handles	
Minimum height above cooker	800 mm	

Refer to 'Positioning the Cooker'.

### Ratings

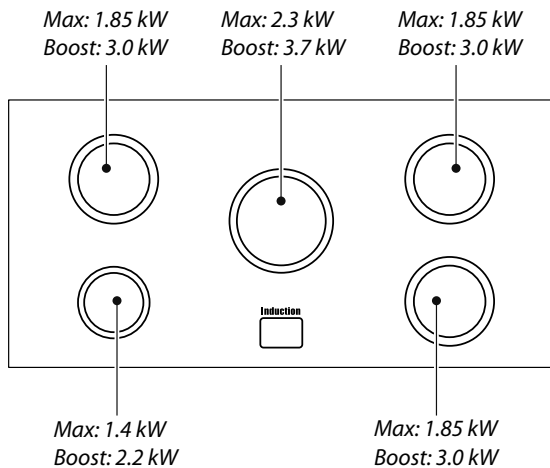

Element/Oven	Left-hand multi-function	Right-hand fan
Fan element	2.5 kW	2.5 kW
Top element	1.2 kW	
Browning element	1.15 kW	
Base element	1.0 kW	

Ovens	Multi-function	Forced air convection
Energy efficiency class on a scale of A (more efficient) to G (less efficient)	A	A
Energy consumption based on standard load	0.90 kWh	0.95 kWh
Usable volume (litres)	68	66
Size	Large	Large
Time to cook standard load	41 minutes	49 minutes
Surface area of the grid	1400 cm <sup>2</sup>	790 cm <sup>2</sup>

Grill	2.3 kW
-------	--------

**Maximum total electrical load at 230V** (approximate total including oven fan, etc.): 18.5 kW



## **AGA RANGEmaster**

Clarence Street, Royal Leamington Spa,  
Warwickshire, CV31 2AD, England.

Tel: +44 (0) 1926 457400 Fax: +44 (0) 1926 450526

E-mail: [consumers@mercuryappliances.co.uk](mailto:consumers@mercuryappliances.co.uk)

